

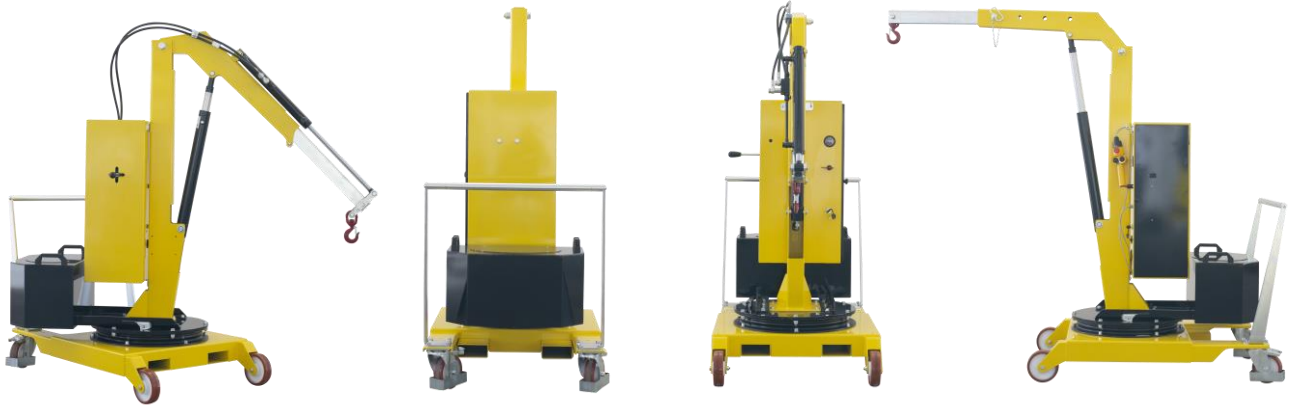

Flexibility, innovation and safety for your work

COUNTERBALANCED 360° SWIVEL CRANES



A complete range of counterbalanced 360° swivel cranes with manual traction, , **with a maximum capacity up to 500 kg and outreach up to 1300 mm**. Hydraulic lever controlled or electric controlled. They represent the most cost-effective and flexible solution for lifting and transporting loads in several applications such as machining centers and machine tools, delivery to assembly lines, assembly operations, goods handling. Thanks to their compact dimensions they are easily maneuverable even at full load and can be moved effortlessly in confined spaces. All components are made in Italy to ensure the highest construction quality and the absence of defects.

The hydraulic system is equipped with a lock valve that prevents the load from falling in case of accidental breakage of the pipes and a rough valve that prevents overloading of the crane.

They are equipped with 2 high-capacity pivoting wheels with bumper mounts and parking brakes and with 2 fixed front wheels with bearings. The frame is made of painted steel and is equipped at the base with 2 useful forklift supports (to lift and transport the crane in complete safety on long distances). The sturdy push handle can be disassembled. There are also 2 handles to easily rotate the ballast. Swivel hook type. Rotating Jib arm with 8 locking positions.

CERTIFICATION AND COMPLIANCE WITH REGULATIONS FOR THE PROTECTION AND SAFETY IN THE WORKPLACE

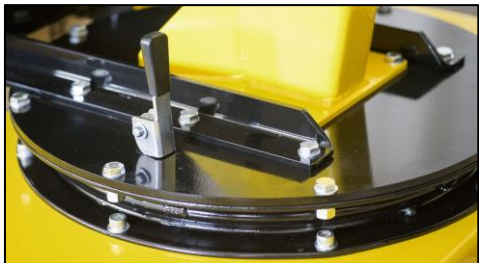

01M2
CAPACITY 200 KG
COUNTERBALANCED SWIVEL GRANE HYDRAULIC LEVER CONTROLLED FAST
LIFT DOUBLE ACTION PUMP - FINE CONTROL DESCENT KNOB



**800 MM FRONT
FOOTPRINT**

Technical data	UM	01M2
Weight	[kg]	400
Max capacity	[kg]	200
Max pressure	[bar]	50
Tank capacity	[Liters]	2
Cylinder stroke	[mm]	470

CAPACITY AND DIMENSIONS WITH STANDARD JIB ARM		
POS.	Length	Capacity
	[mm]	01M2 [kg]
1	365	200
2	500	170
3	635	150
4	770	130

CAPACITY WITH OPTIONAL EXTENDED JIB ARM		
POS.	Length	Capacity
	[mm]	01M2 [kg]
1	865	92
2	1000	85
3	1135	78
4	1270	71

The 01M2 is equipped with a lever controlled fast and lightweight lift double action pump .

The control descent knob make it possible to adjust the descent speed.

The arm is extendable in 4 positions and an optional arm extension is available to get a maximum outreach of 1270 mm.

The model 01M2 model being a crane with manual lifting does not require a third-party certification according to current legislation or obligation of periodic checks.



Detail of the hand pump with rod housing support and knurled knob

01M2
TECHNICAL DRAWINGS, DIMENSIONS AND CAPACITIES
 The most cost effective and flexible crane

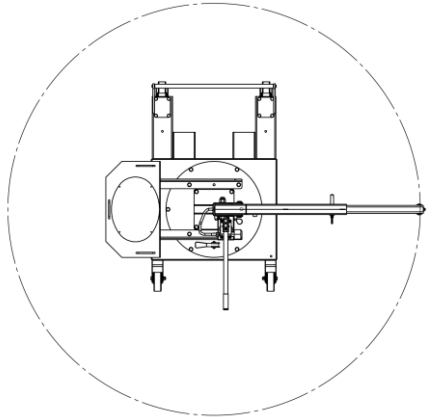
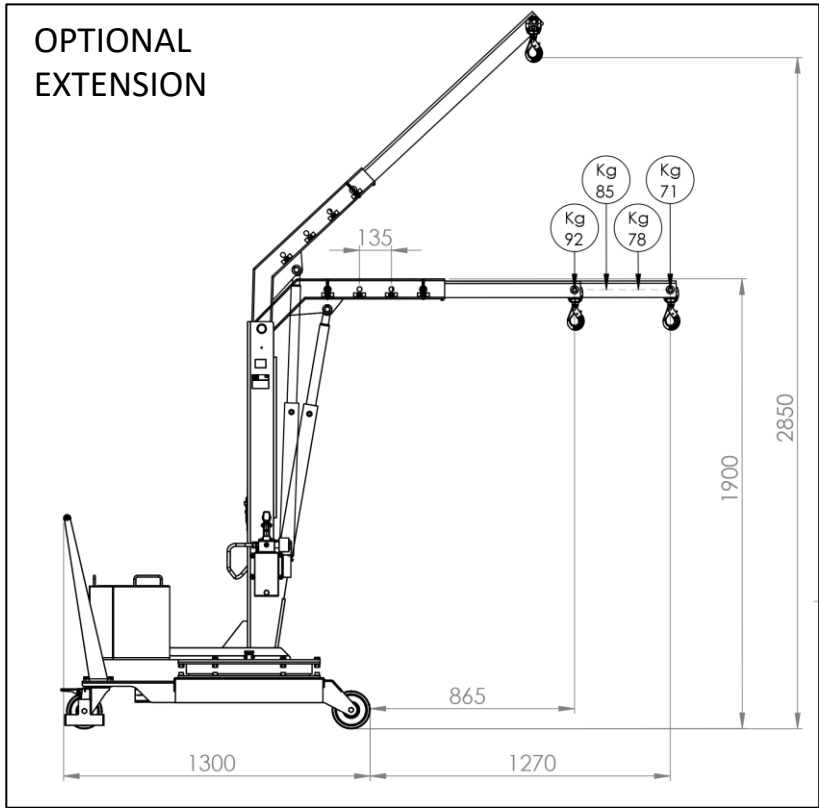
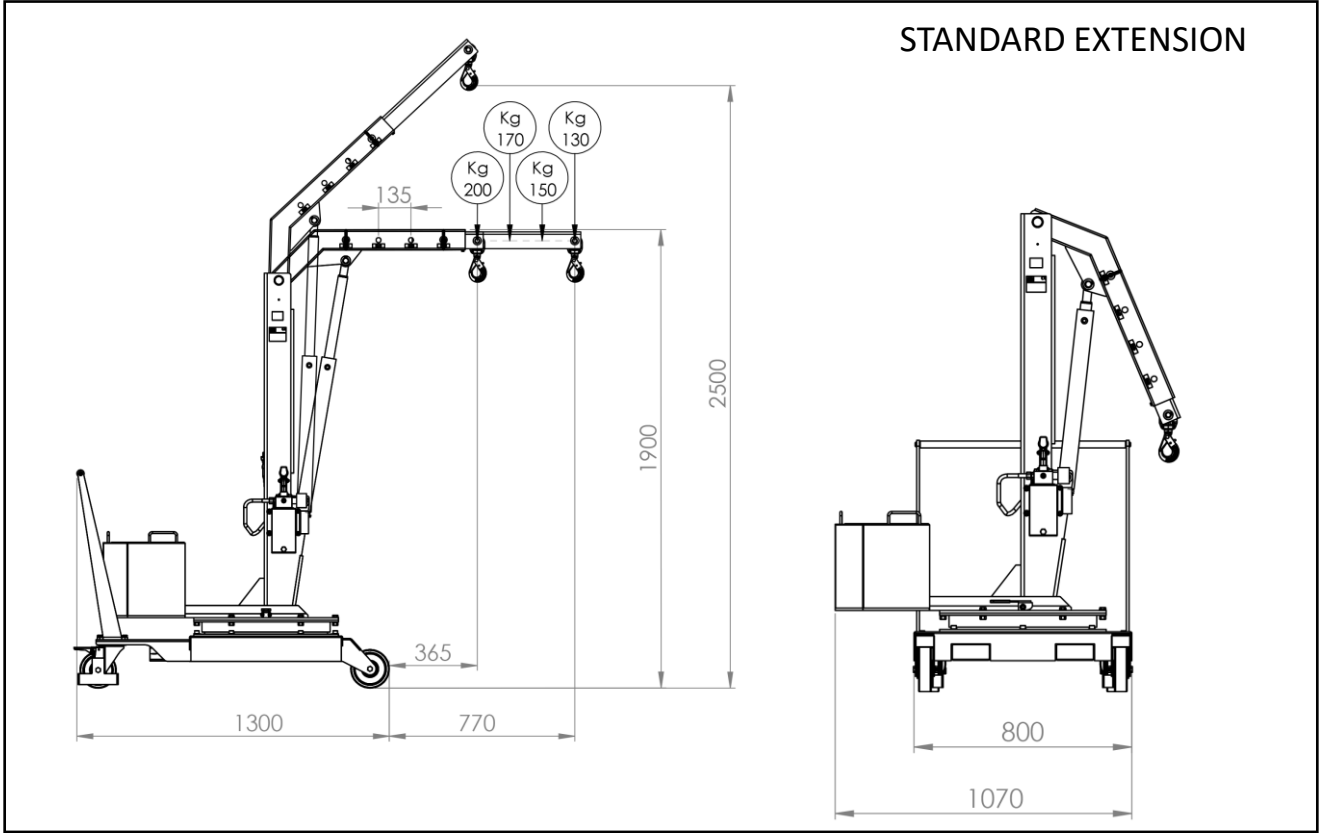

01B2
CAPACITY 200 KG
COUNTEDBALANCED SWIVEL CRANE LIFT/LOWER POWERED CONTROLLED
SINGLE SPEED NOT ADJUSTABLE



Technical data	UM	01B2
Weight	[kg]	440
Max capacity	[kg]	200
Max pressure	[bar]	50
Tank capacity	[Liters]	2,5
Cylinder stroke	[mm]	470

1 battery	[V]	12
	[A]	80
Battery charger	[V]	220
	[A]	12

CAPACITY AND DIMENSIONS WITH STANDARD JIB ARM		
POS.	Length	Capacity
	[mm]	01B2 [kg]
1	365	200
2	500	170
3	635	150
4	770	130

CAPACITY WITH OPTIONAL EXTENDED JIB ARM		
POS.	Length	Capacity
	[mm]	01B2 [kg]
1	865	92
2	1000	85
3	1135	78
4	1270	71

Model 01B2 is equipped with a lift/lower system controlled by pendant push button with emergency stop.
Built-in high-frequency charger.
Charge level indicator. Battery 12V 80A.

The arm is extendable in 4 positions and an optional arm extension is available to get a maximum outreach of 1270 mm.

Model 01B2, being a crane with a maximum capacity of 200 kg, does not require a third-party certification according to current legislation.



01B2
TECHNICAL DRAWINGS, DIMENSIONS AND CAPACITIES
 800 mm front footprint

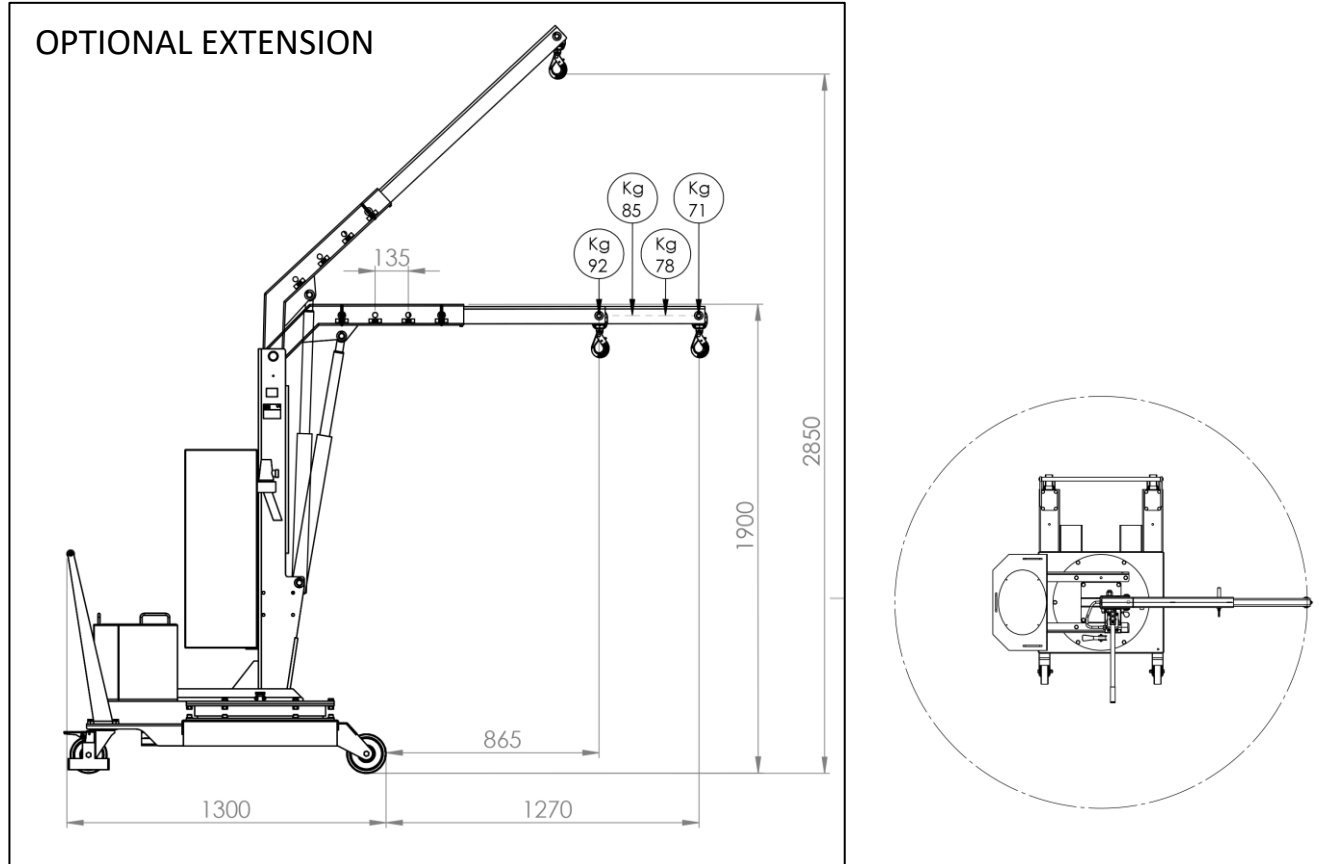
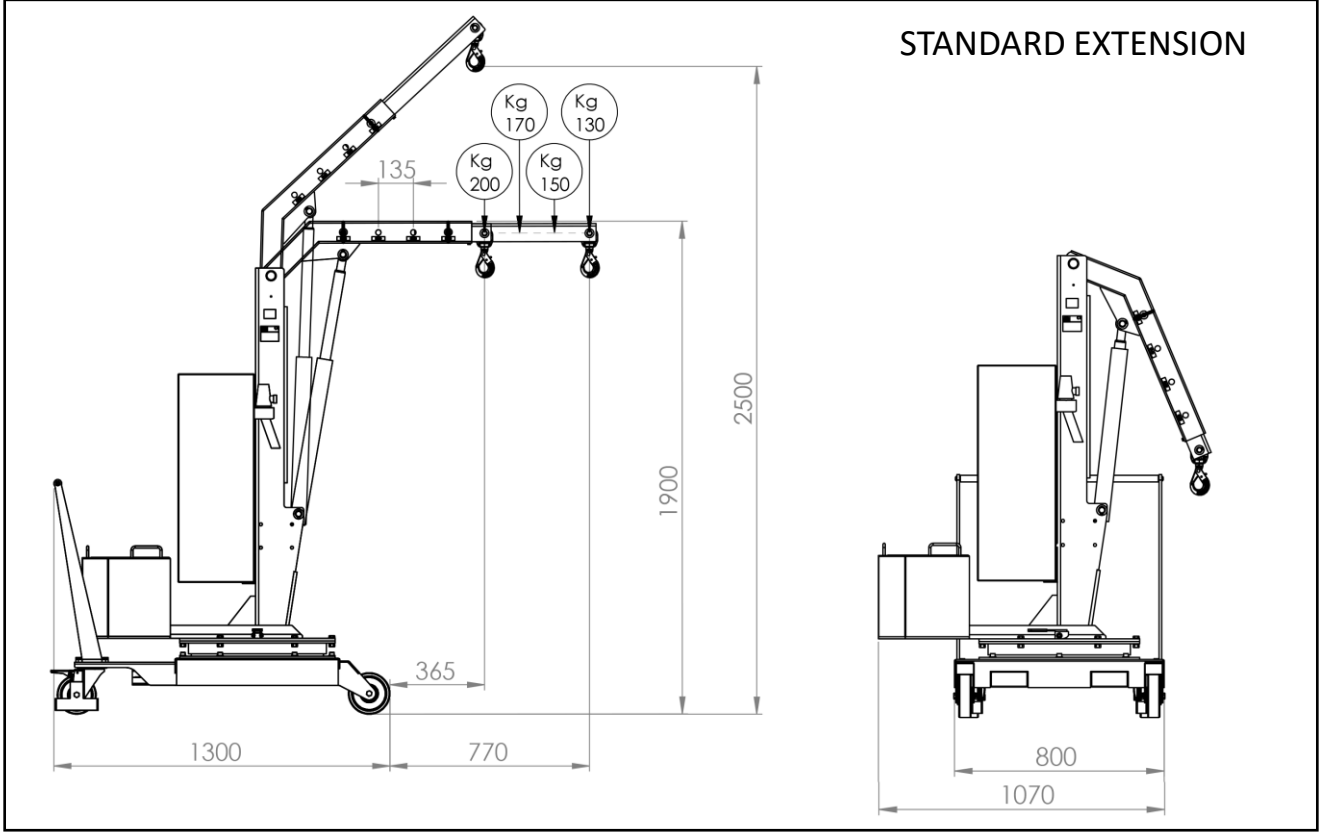

01B2P
CAPACITY 200 KG
COUNTERBALANCED SWIVEL CRANE, ONE SPEED LIFT ELECTRIC POWERED ,
LOWER CONTROLLED BY PENDANT PROGRESSIVE LEVER



Technical data	UM	01B2P
Weight	[kg]	440
Max capacity	[kg]	500
Max pressure	[bar]	50
Tank capacity	[Liters]	2,5
Cylinder stroke	[mm]	470

Model 01B2P is equipped with a pendant lever for lifting a load at a single speed and operating a progressive descent. This requirement is indispensable when millimeter accuracy is required during the positioning of the load.

The arm is extendable in 4 positions and an optional arm extension is available to get a maximum outreach of 1270 mm.

Built-in high-frequency charger. Charge level indicator. Battery 12V 80A.

CAPACITY AND DIMENSIONS WITH STANDARD JIB ARM		
POS.	Length [mm]	Capacity
		01B2P [kg]
1	365	500
2	500	420
3	635	370
4	770	320



CAPACITY WITH OPTIONAL EXTENDED JIB ARM		
POS.	Length [mm]	Capacity
		01B2P [kg]
1	865	220
2	1000	200
3	1135	180
4	1270	160

Model 01B2P, being a crane with a maximum capacity of 200 kg, does not require a third-party certification according to current legislation.

1 battery	[V]	12
	[A]	80
Battery charger	[V]	220
	[A]	12

01B2P
TECHNICAL DRAWINGS, DIMENSIONS AND CAPACITIES
 800 mm front footprint

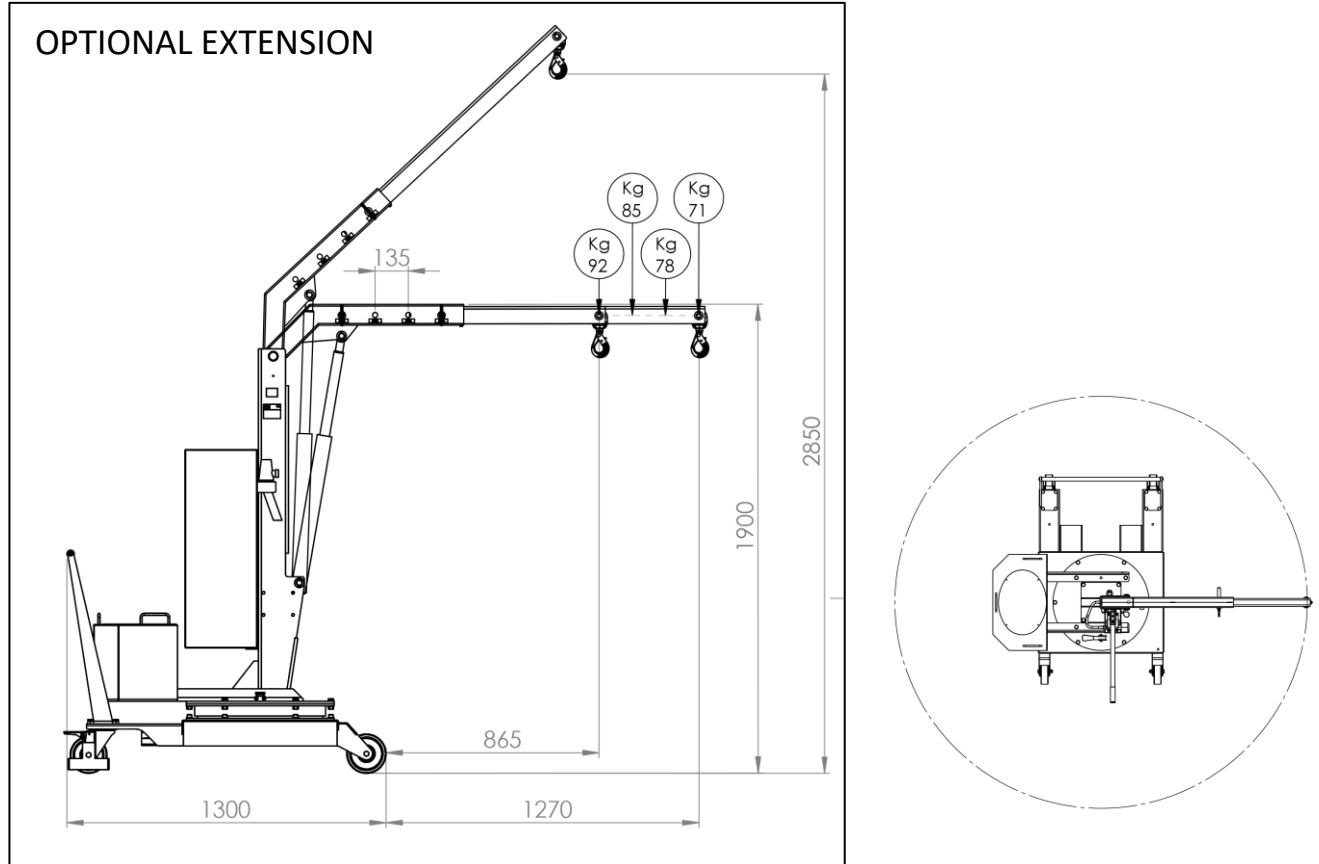
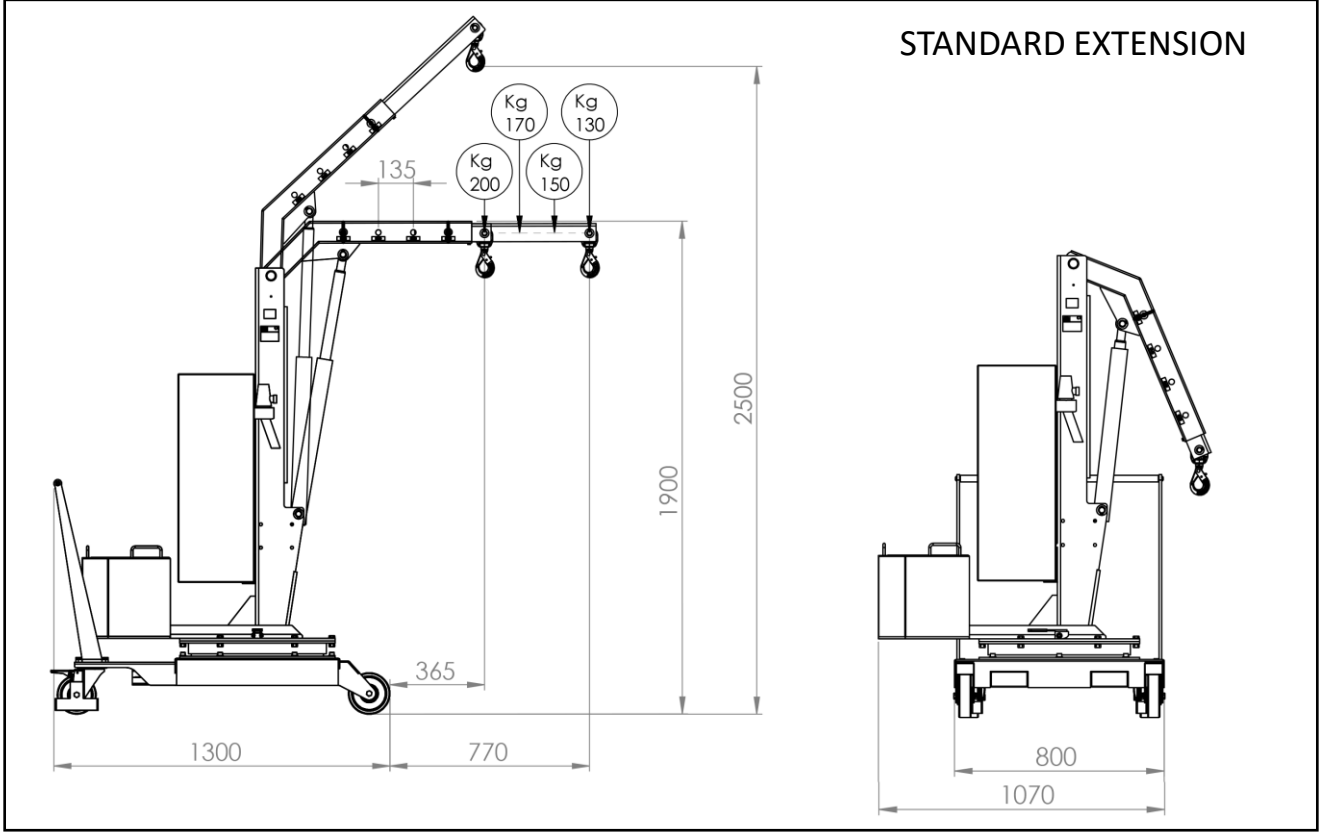

01B2SE
CAPACITY 200 KG
COUNTERBALANCED SWIVEL CRANE , POWERED LIFT /LOWER & POWERED
EXTEND/RETRACT JIB ARM WITH PROGRESSIVE SPEED



Technical data	UM	01B2SE
Weight	[kg]	445
Max capacity	[kg]	200
Max pressure	[bar]	60
Tank capacity	[Liters]	2,5
Cylinder stroke	[mm]	470

Model 01B2SE is equipped with an electric controlled jib arm . It is equipped with a 4 way fine control lever controls for :

- Lifting the jib arm
- Lowering the jib arm
- Extending the jib arm
- Retracting the jib arm

All movements (arm and extension) are electric controlled, progressive and adjustable by the operator with extreme precision. Controlled descent system with the engine off.

01B2SE CAPACITY AND DIMENSIONS WITH STANDARD JIB ARM	
Length	Capacity
[mm]	[kg]
from 410toA 810	from 200 to 130

Model 01B2SE, being a crane with a maximum capacity of 200 kg, does not require a third-party certification according to current legislation.

01B2SE CAPACITY WITH OPTIONAL EXTENDED JIB ARM	
Length	Capacity
[mm]	[kg]
from 912 to 1312	from 92 to 71

1 battery	[V]	12
	[A]	80
Battery charger	[V]	220
	[A]	12

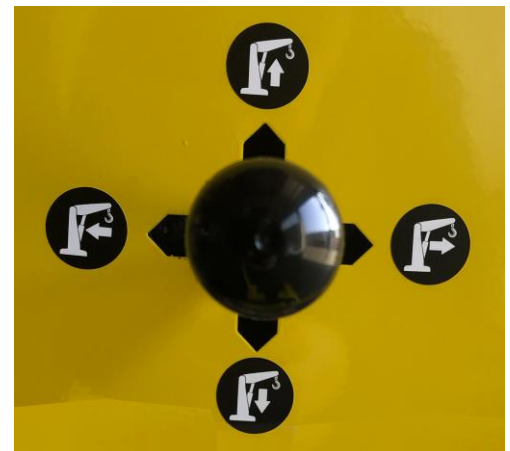

Detail of the 4 way fine control lever

01B2SE

TECHNICAL DRAWINGS, DIMENSIONS AND CAPACITIES
The mini crane with electric controlled extension and a footprint of 800 mm

STANDARD EXTENSION

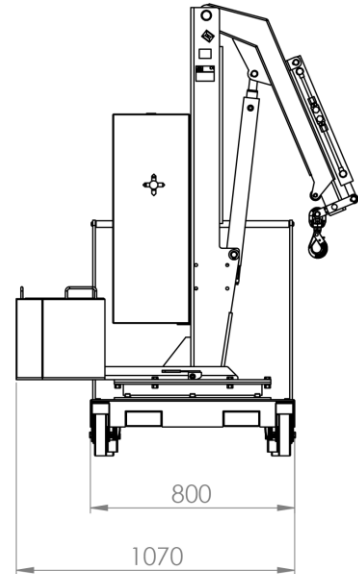
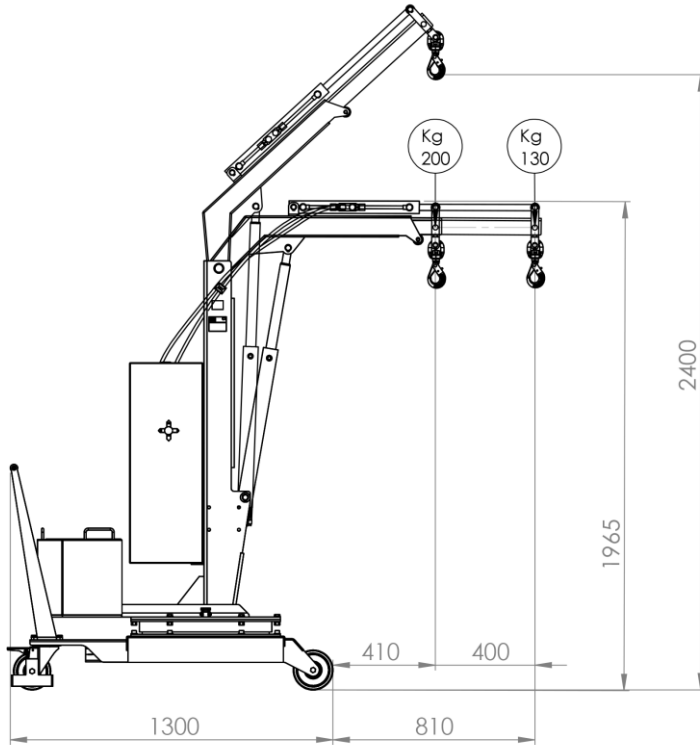

OPTIONAL EXTENSION

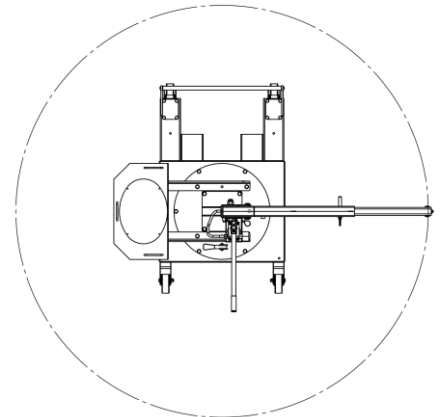
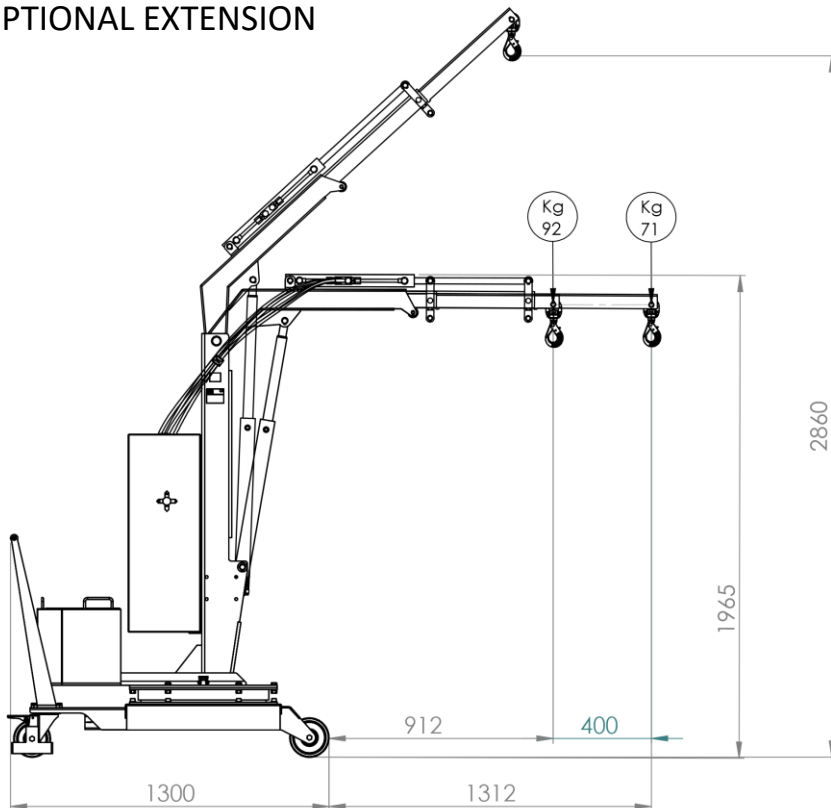

01M5
CAPACITY 500 KG
COUNTERBALANCED SWIVEL GRANE HYDRAULIC LEVER CONTROLLED FAST LIFT DOUBLE ACTION PUMP - FINE CONTROL DESCENT KNOB



SAFE, RELIABLE AND ERGONOMIC FOR THE PROTECTION OF WORKERS

Technical data	UM	01M5
Weight	[kg]	600
Max capacity	[kg]	500
Max pressure	[bar]	140
Tank capacity	[Liters]	2
Cylinder stroke	[mm]	470

The 01M5 is equipped with a lever controlled fast and lightweight lift double action pump .
 The control descent knob make it possible to adjust the descent speed.

CAPACITY AND DIMENSIONS WITH STANDARD JIB ARM		
POS.	Length	Capacity
	[mm]	[kg]
1	365	500
2	500	420
3	635	370
4	770	320

The arm is extendable in 4 positions and an optional arm extension is available to get a maximum outreach of 1270 mm.

CAPACITY WITH OPTIONAL EXTENDED JIB ARM		
POS.	Length	Capacity
	[mm]	[kg]
1	865	220
2	1000	200
3	1135	180
4	1270	160

The model 01M5 model being a crane with manual lifting does not require a third-party certification according to current legislation or obligation of periodic checks.

Detail of the hand pump with rod housing support and knurled knob



01M5

TECHNICAL DRAWINGS, DIMENSIONS AND CAPACITIES

The most cost effective and flexible crane

STANDARD EXTENSION

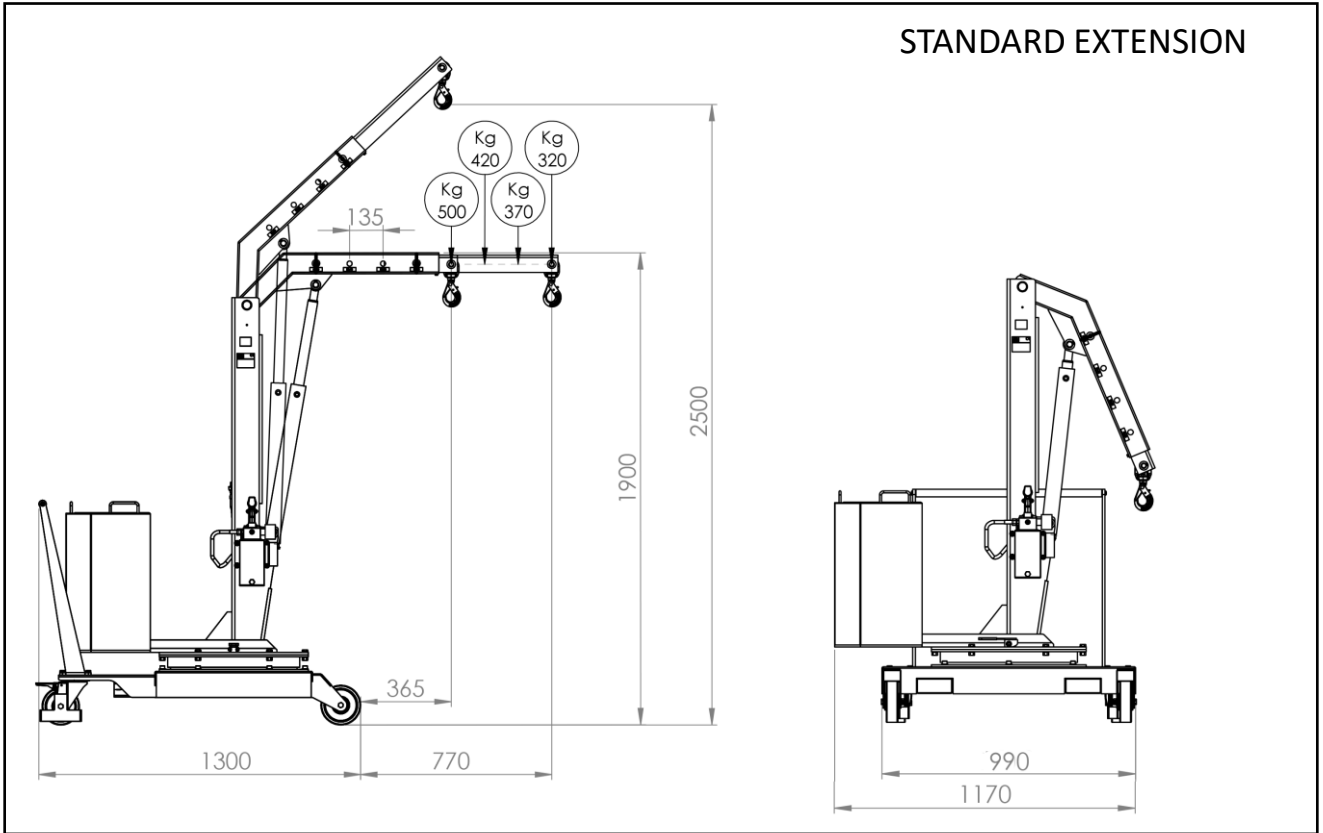

OPTIONAL EXTENSION

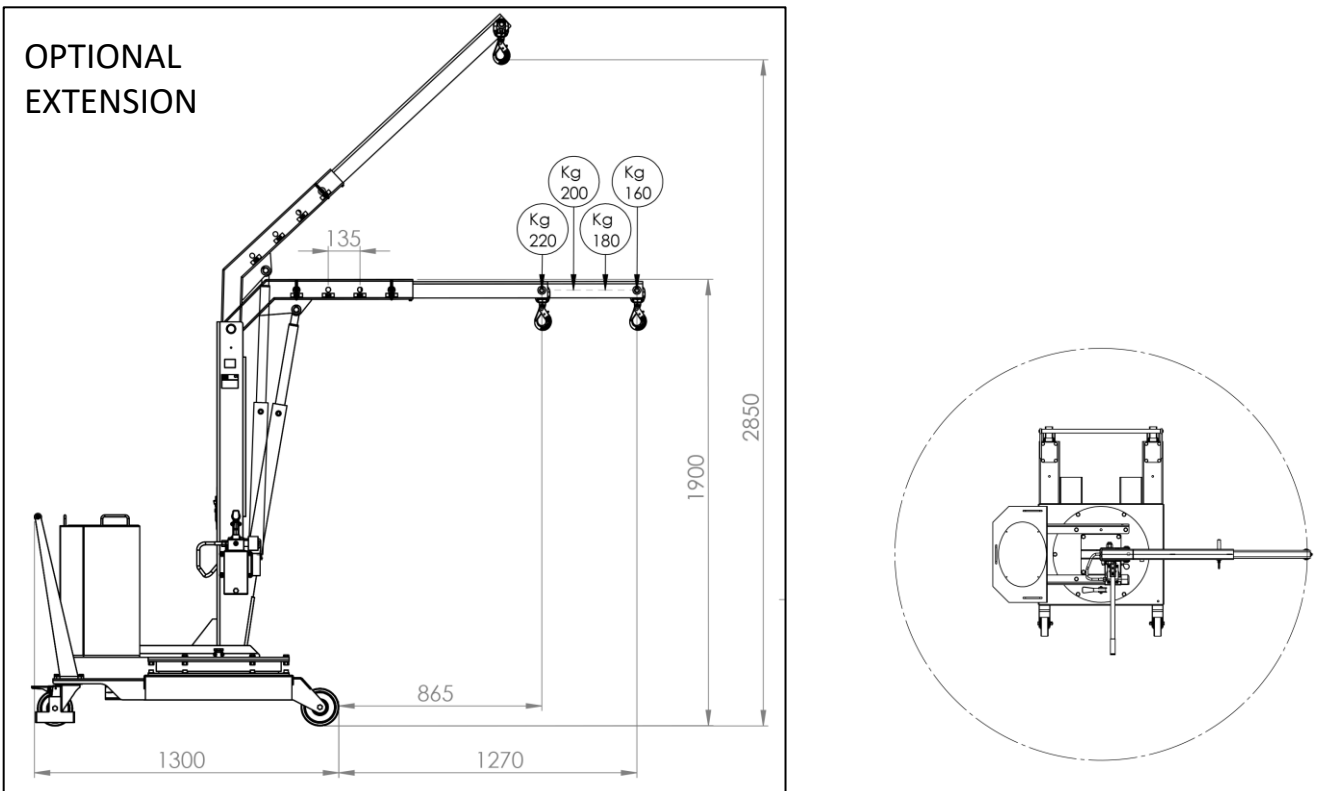

01B5
CAPACITY 500 KG
COUNTEDBALANCED SWIVEL GRANE LIFT/LOWER POWERED CONTROLLED
SINGLE SPEED NOT ADJUSTABLE

Technical data	UM	01B5
Weight	[kg]	640
Max capacity	[kg]	500
Max pressure	[bar]	140
Tank capacity	[Liters]	2,5
Cylinder stroke	[mm]	470

CAPACITY AND DIMENSIONS WITH STANDARD JIB ARM		
POS.	Length [mm]	Capacity
		01B5 [kg]
1	365	500
2	500	420
3	635	370
4	770	320

CAPACITY WITH OPTIONAL EXTENDED JIB ARM		
POS.	Length [mm]	Capacity
		01B5 [kg]
1	865	220
2	1000	200
3	1135	180
4	1270	160



Model 01B5 is equipped with a lift/lower system controlled by pendant push button with emergency stop.



The arm is extendable in 4 positions and an optional arm extension is available to get a maximum outreach of 1270 mm.

Built-in high-frequency charger.
Charge level indicator. Battery 12V 80A.

1 battery	[V]	12
	[A]	80
Battery charger	[V]	220
	[A]	12

01B5

TECHNICAL DRAWINGS, DIMENSIONS AND CAPACITIES

Recommended for lifting operations that do not require an accurate load positioning in the descent phase

STANDARD EXTENSION

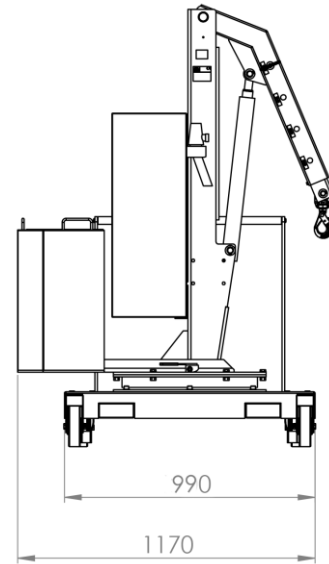
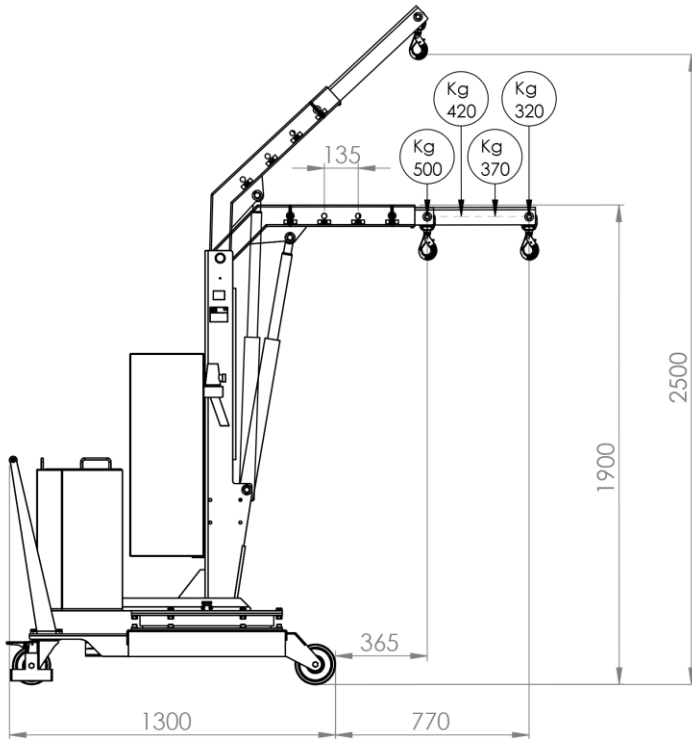

OPTIONAL EXTENSION

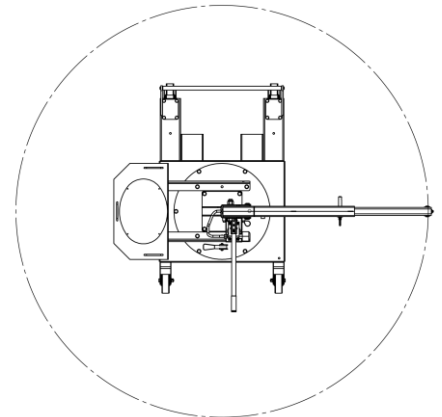
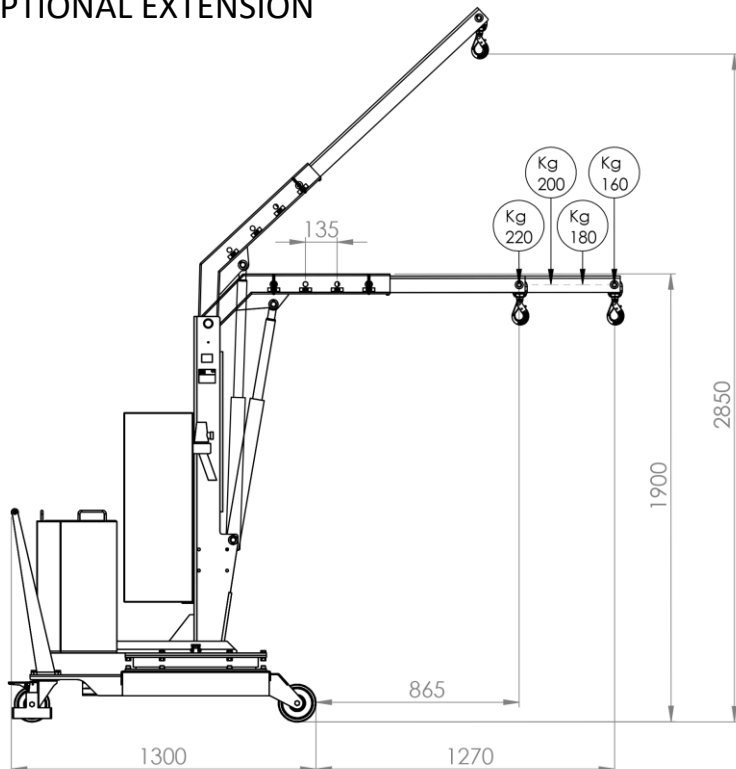

01B5P
CAPACITY 500 KG
COUNTERBALANCED SWIVEL CRANE, ONE SPEED LIFT ELECTRIC POWERED ,
LOWER CONTROLLED BY PENDANT PROGRESSIVE LEVER



Technical data	UM	01B5P
Weight	[kg]	640
Max capacity	[kg]	500
Max pressure	[bar]	140
Tank capacity	[Liters]	2,5
Cylinder stroke	[mm]	470

Model 01B5P is equipped with a pendant lever for lifting a load at a single speed and operating a progressive descent. This requirement is indispensable when millimeter accuracy is required during the positioning of the load.

The arm is extendable in 4 positions and an optional arm extension is available to get a maximum outreach of 1270 mm.

Built-in high-frequency charger. Charge level indicator. Battery 12V 80A.

CAPACITY AND DIMENSIONS WITH STANDARD JIB ARM		
POS.	Length [mm]	Capacity
		01B5P [kg]
1	365	500
2	500	420
3	635	370
4	770	320

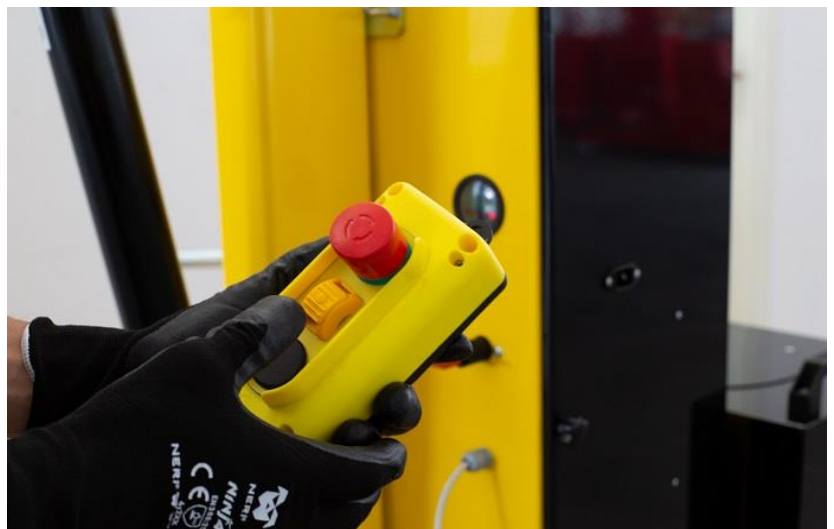

CAPACITY WITH OPTIONAL EXTENDED JIB ARM		
POS.	Length [mm]	Capacity
		01B5P [kg]
1	865	220
2	1000	200
3	1135	180
4	1270	160

1 battery	[V]	12
	[A]	80
Battery charger	[V]	220
	[A]	12

01B5P

TECHNICAL DRAWINGS, DIMENSIONS AND CAPACITIES

Recommended for operations where an accurate load positioning is needed

STANDARD EXTENSION

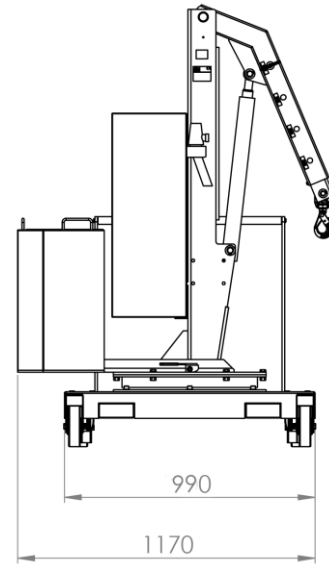
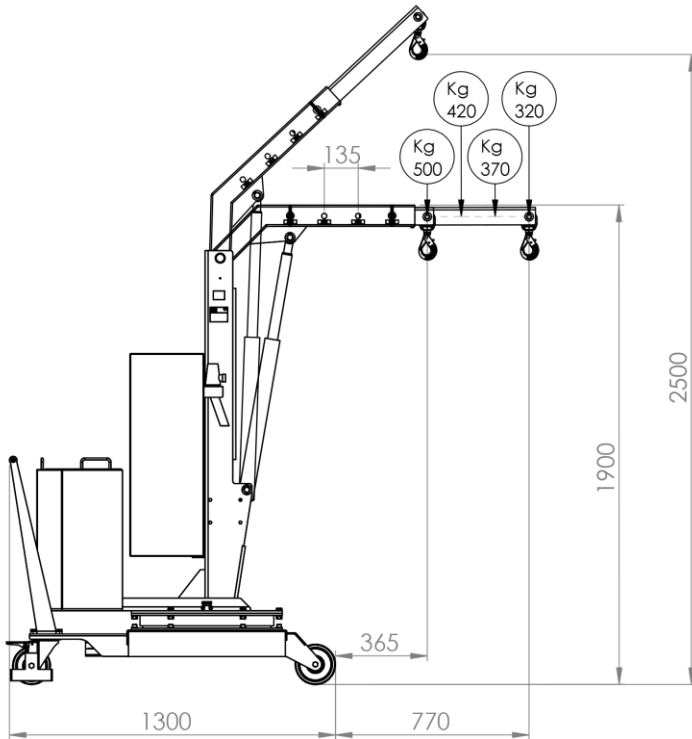

OPTIONAL EXTENSION

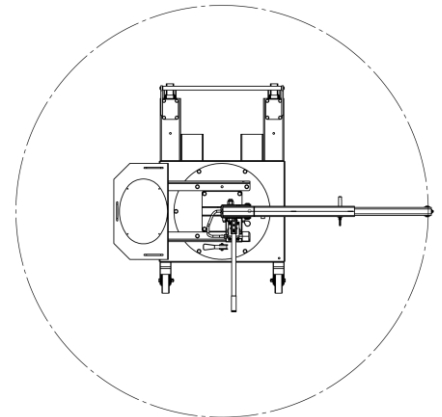
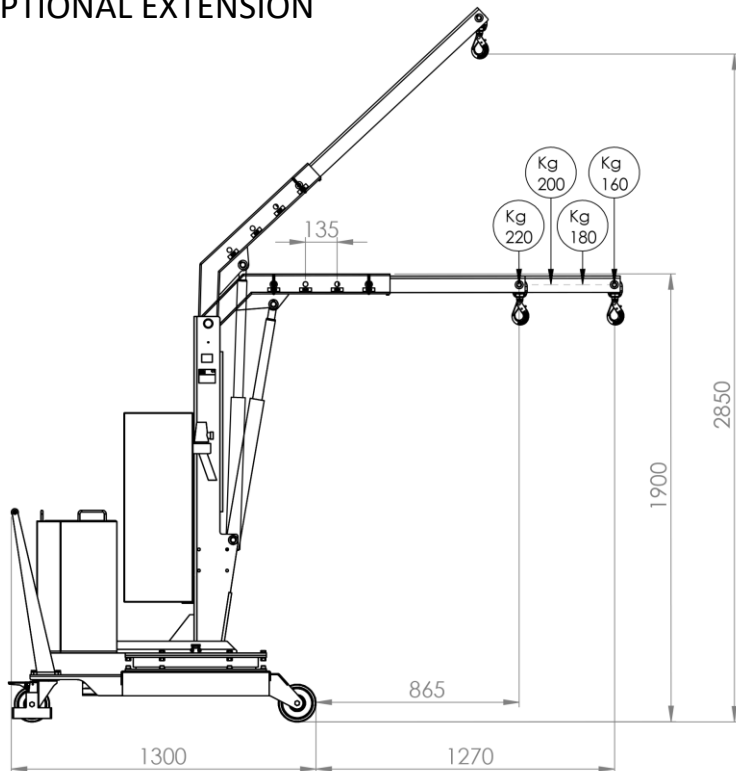

01B5SE
CAPACITY 500 KG
COUNTERBALANCED SWIVEL CRANE , POWERED LIFT /LOWER & POWERED
EXTEND/RETRACT JIB ARM WITH PROGRESSIVE SPEED



Technical data	UM	01B5SE
Weight	[kg]	645
Max capacity	[kg]	500
Max pressure	[bar]	60
Tank capacity	[Liters]	2,5
Cylinder stroke	[mm]	470

01B5SE CAPACITY AND DIMENSIONS WITH STANDARD JIB ARM	
Length	Capacity
[mm]	[kg]
from 410 to 810	from 500 to 320

01B5SE CAPACITY WITH OPTIONAL EXTENDED JIB ARM	
Length	Capacity
[mm]	[kg]
from 912 to 1312	from 220 to 160

1 battery	[V]	12
	[A]	80
Battery charger	[V]	220
	[A]	12

Model 01B5SE is equipped with an electric controlled jib arm . It is equipped with a 4 way fine control lever controls for :

- Lifting the jib arm
- Lowering the jib arm
- Extending the jib arm
- Retracting the jib arm

All movements (arm and extension) are electric controlled, progressive and adjustable by the operator with extreme precision. Controlled descent system with the engine off.

Model 01B5SE is the most popular model for awkward placements from the ground onto 3D machines, lathes, over perimeter protections, narrow openings, etc., thanks to its 360° pivoting and in all those applications where there is no space to move the load with a forklift or other large sizes lifting equipment.

Detail of the 4 way fine control lever



01B5SE

TECHNICAL DRAWINGS, DIMENSIONS AND CAPACITIES

The right crane for endless applications
and the best performance

STANDARD EXTENSION

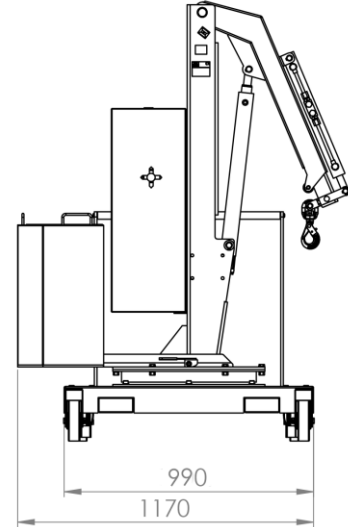
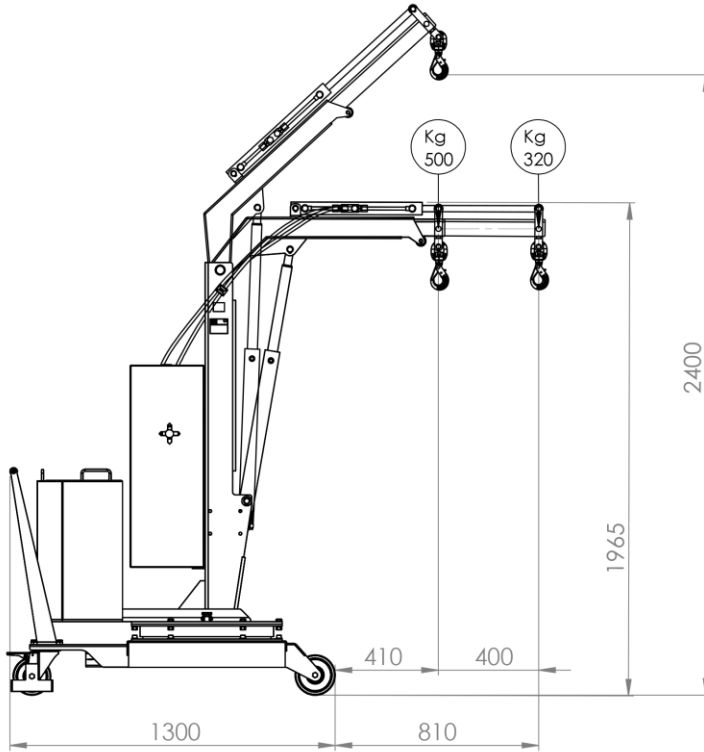

OPTIONAL EXTENSION

