



BULL 2
BULL 4
CAB



ELECTRIC TRACTORS

This tractor series, which we have been manufacturing for over ten years, is continuously upgraded and improved. Thousands of these machines have been produced and are still on the market.

Its success stems from its ability to deal with the many different requirements of the industrial handling sector.

These tractors can work both indoors and outdoors thanks to the different versions available: with tyres or superelastic wheels, with or without cab. So many optionals have been added to these machines over the years that now, almost everything has already been designed and is available.

Both BULL 2, with its 2-ton towing capacity and BULL 4, with its 4-ton towing capacity, are three-wheel tractors able to cover medium distances and feature an electronic system that monitors both acceleration and regenerative braking. Besides being extremely convenient, this type of braking system safeguards the brakes, which last longer and provide a better performance.



BULL 2 BULL 4 CAB

CHASSIS: in electric arc welded tubular steel forming a rigid bearing structure.

DRIVE UNIT: comprises a differential specifically designed for reliable and silent operation and a long-lasting, high-performance motor.

DRIVER'S POSITION: designed to provide an optimum level of comfort, includes a generously sized seat and storage compartment. The dashboard features an instrument that signals the battery charge status and hours worked. Large steering wheel. Accelerator pedal and brake pedal. Steering system: mechanical reduction. Precise yet light. Controls the front wheel at an angle allowing the machine to reverse within a very small space.

WHEELS: three, with good size tyres. Superelastic rubber tyres on request, guaranteeing long life and wheel grip without foregoing driver comfort. No-marking wheels are available on request.

ELECTRIC SYSTEM: comprising an electronic control unit and closed remote control switches. Provides excellent control over movements. Designed to prevent operating faults, it functions during both acceleration and braking, which is regenerative. Automatic electric parking brake.

SAFETY DEVICES: the machine conforms to the accident prevention regulations in force as to components, performance and stability.

30.01.03.06

stitaliana

CHARACTERISTICS		dim.un.	
Manufacturer			
Model		Bull2	Bull4
Platform loading capacity	Nominal capacity	Kg.	-----
Pull capacity	Load nominal capacity	Kg.	2000 4000
Power type	Electric/Endothermic		Electric Electric
Control type	Pedestrian/stand-on/Seated		Seated Seated
Tyres	Pn - pneum. / se - superel.		Se-Se Se-Se
Wheels	Number front/rear X=drive	Nr.	3 - 1/2x 3 - 1/2x
Platform dimensions	L x B (lenght x width)	mm.	-----
DIMENSIONS			
	h= machine body hight	mm.	-----
	L= lenght	mm.	1500 1600
	B=width	mm.	900 930
	h 3 = feet panel hight	mm.	310 340
	h 4 = steering/handle hight	mm.	940 990
	h 2 = thiller hight	-----	-----
	h 5 = seat hight	mm.	450 520
	h 6 = turning light hight	mm.	1620 1620
	h 7 = cabin turning light hight	mm.	1940 2010
	h 1 = cabin hight	mm.	1810 1880
	h 9 = cabin width	mm.	890 890
Turning radius	R1= front min. external	mm.	1400 1500
	R2=rear min. external	mm.	1000 1000
	R3=rear min.internal	mm.	120 120
Aisle width	U-turn	mm.	2200 2300
Hook hight	s = hook center to ground	mm.	220-350-490 240-380-520
PERFORMANCE			
Speed	Without / with load	Km./h	12-4 12-4
Tractive effort	Continuative work 60'	N.	1200 1800
	Max in plane x 5"	N.	1800 2700
Gradeability	Without/width	%	10-5 12-4
Weight	With battery	Kg.	550 740
Axles load	Front/rear with battery	Kg.	160-390 175-495
TRACTION			
Wheels	Front diam./ width	mm.	312-116 360-150
	Rear diam./ width	mm.	414-121 414-150
Wheelbase	y = pitch	mm.	1070 1170
Trach	C posterior wheels center	mm.	710 710
Ground clearance	h= clearance at half chassis	mm.	240 250
Working brake	Mecc./hydraul./elettr.		Hydraulic Hydraulic
	Brake axles number	N.	1 1
Parking brake	Mecc./hydraul./elettr.		Elettr. Elettr.
Suspensions	Spring/laf spring/schock absorber		-----
POWER SUPPLY			
Battery	Type	Reinforced	Reinforced
	Capacity	V./Ah.	24-250(C5) 24-300(C5)
	Weight	Kg.	220 220
Electric motor	Translation,power S2=60°	Kw.	2,0 AC 3,5 AC
Electric system	electronic control	Inverter AC	Inverter AC Inverter AC
Steering	Mecc./hydraul./elettr.		Mechanics Mechanics
Transmission	Mecc.		Mechanics Mechanics
Towing hook	manual - automatic		Manual Manual
Autonomy	working hours witm medium work	h.	6-8 6-8

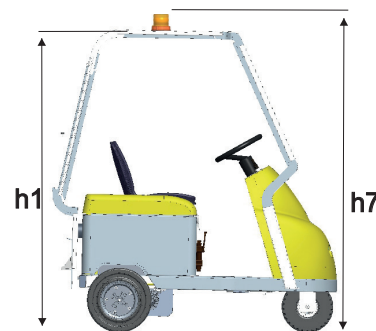
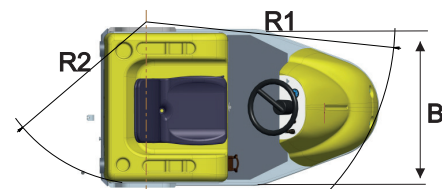
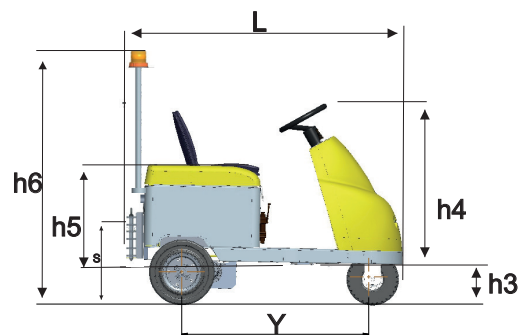

DEC Spa • Via Omero 89 - 41123 Modena - Italy
Tel. +39 059 373222 - Fax +39 059 374199 - info@dec-modena.com
www.dec-modena.com