

**COUNTERBALANCED CRANES WITH FIX JIB ARM – MANUAL OR ELECTRIC CONTROLLED JIB EXTENSION – LARGE CAPACITY**



A complete range of counterbalanced cranes with manual traction, , **with a maximum capacity up to 1.000 kg and outreach up to 2.000 mm**. Hydraulic lever controlled fast lift double action pump or electric controlled. They represent the most cost-effective and flexible solution for lifting and transporting loads in several applications such as machining centers and machine tools, delivery to assembly lines, assembly operations, goods handling. Thanks to their minimum frontal footprint of just 800mm they can be moved in narrow lanes and spaces and are easily maneuverable even at full load without efforts. All components are made in Italy to ensure the highest construction quality and the absence of defects.

**The hydraulic system is equipped with a lock valve that prevents the load from falling in case of accidental breakage of the pipes and a rough valve that prevents overloading of the crane.**

Tiller arm equipped with gas spring and double wheels Ø 200 mm with ball bearings and braking system; 2 fixed front wheels Ø 250 mm with bearings to make it easy to move.

The frame is made of painted steel and is equipped at the base with 2 useful forklift supports to lift and transport the crane safely on long distances. 360 ° swivel hook type.



**CERTIFICATION AND COMPLIANCE WITH REGULATIONS FOR THE PROTECTION AND SAFETY IN THE WORKPLACE**

**GZ1000**  
CAPACITY 1000 KG  
**COUNTERBALANCED CRANE FIX JIB ARM – HYDRAULIC LEVER CONTROLLED**  
**FAST LIFT DOUBLE ACTION PUMP – FINE CONTROL DESCENT KNOB**



<b>Technical data</b>	UM	GZ1000
Weight	[kg]	1150
Max capacity	[kg]	1000
Max pressure	[bar]	160
Tank capacity	[Liters]	3
Cylinder stroke	[mm]	550

Model GZ1000 is equipped with a lever controlled fast lift and lightweight double action pump .

The control descent knob make it possible to adjust the descent speed. The arm is extendable in 4 positions and an optional arm extension is available to get a maximum outreach of 2000 mm.

**Model GZ1000 being a crane with manual lifting does not require a third-party certification according to current legislation or obligation of periodic checks.**

CAPACITY AND DIMENSIONS WITH STANDARD JIB ARM

POS.	Length	Capacity
	[mm]	[kg]
1	650	1000
2	850	835
3	1050	670
4	1250	500

800mm front footprint



Detail of the hand pump with rod housing support and knurled knob



CAPACITY WITH OPTIONAL EXTENDED JIB ARM

POS.	Length	Capacity
	[mm]	[kg]
1	1400	450
2	1600	390
3	1800	325
4	2000	275

**GZ1000**  
**TECHNICAL DRAWINGS, DIMENSIONS AND CAPACITIES**  
The most cost effective and flexible crane

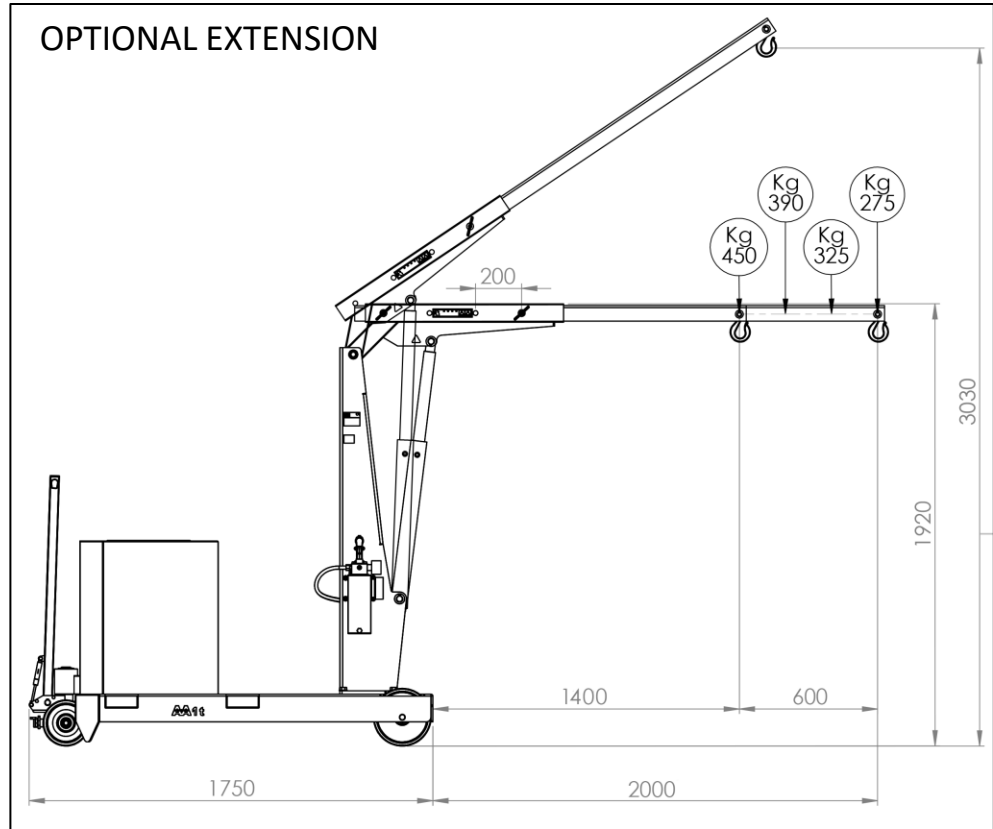
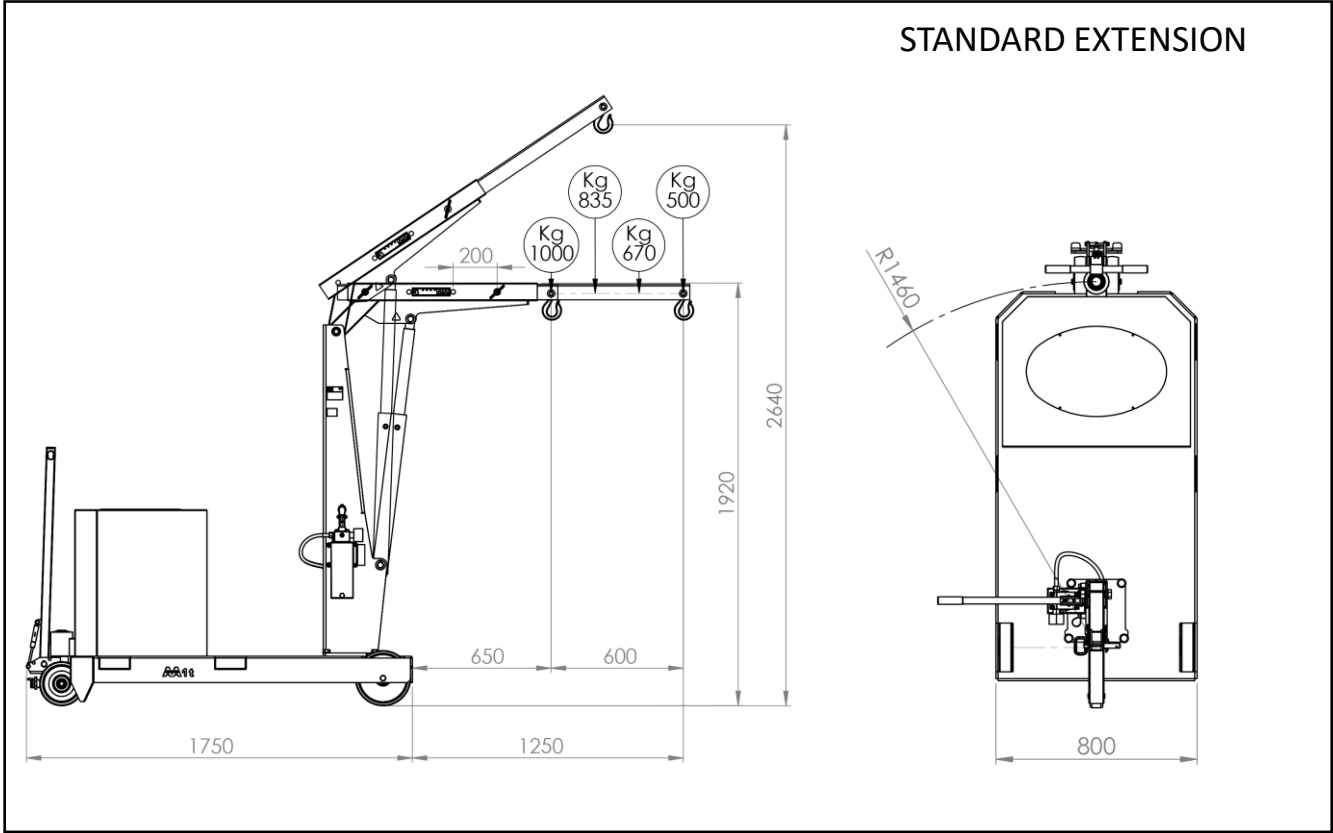

For an unlimited number of applications.

No obligation to carry out periodic verification.

**GZ1000**  
**TECHNICAL DRAWINGS, DIMENSIONS AND CAPACITIES**  
 The most cost effective and flexible crane

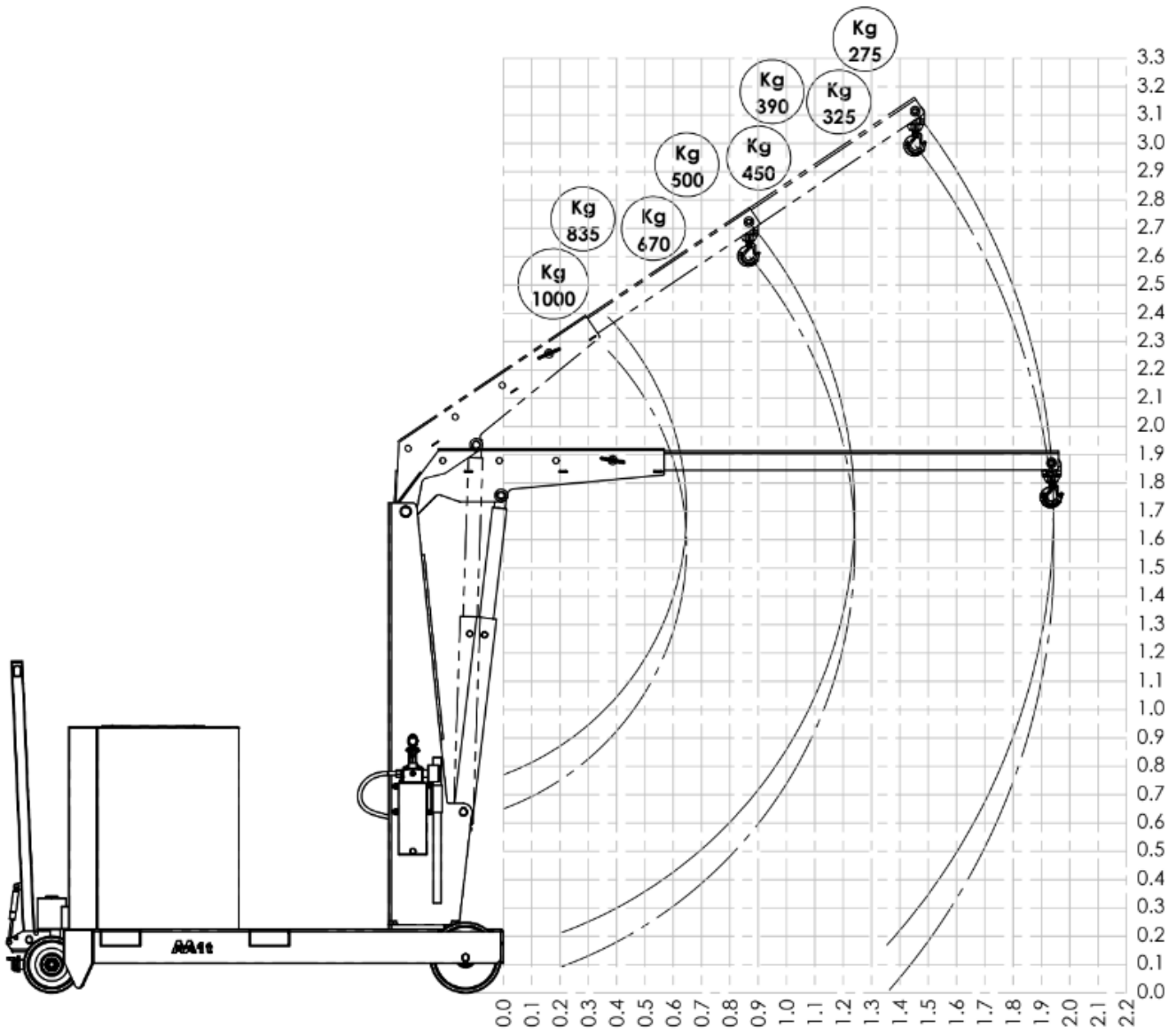

**GZ1000B**  
CAPACITY 1000 KG  
COUNTERBALANCED CRANE – FIX JIB ARM – SINGLE SPEED POWERED  
LIFT/LOWER JIB ARM



CAPACITY AND DIMENSIONS WITH STANDARD JIB ARM		
POS.	Length	Capacity
	[mm]	GZ1000B [kg]
1	650	1000
2	850	835
3	1050	670
4	1250	500

Technical data	UM	GZ1000B
Weight	[kg]	1190
Max capacity	[kg]	1000
Max pressure	[bar]	160
Tank capacity	[Liters]	3
Cylinder stroke	[mm]	550

CAPACITY WITH OPTIONAL EXTENDED JIB ARM		
POS.	Length	Capacity
	[mm]	GZ1000B [kg]
1	1400	450
2	1600	390
3	1800	325
4	2000	275

Nr 1 Battery	[V]	12
	[A]	80
Charger	[V]	220
	[A]	12

Model GZ1000B is equipped with a single speed lift/lower system controlled by pendant push button with emergency stop. Built-in high-frequency charger. Charge level indicator. Battery 12V 80A. The arm is extendable in 4 positions and an optional arm extension is available to get a maximum outreach of 2000 mm.



# GZ1000B

## TECHNICAL DRAWINGS, DIMENSIONS AND CAPACITIES

Recommended for lifting operations that do not require an accurate load positioning in the descent phase

### STANDARD EXTENSION

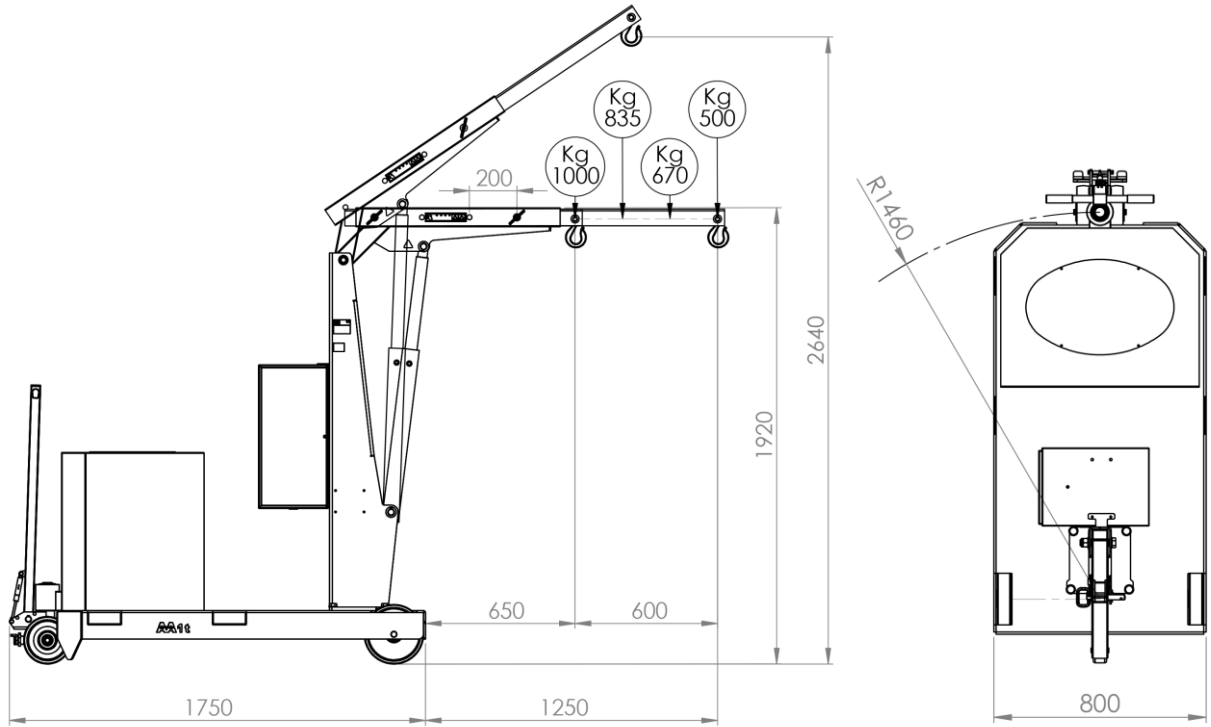

### OPTIONAL EXTENSION

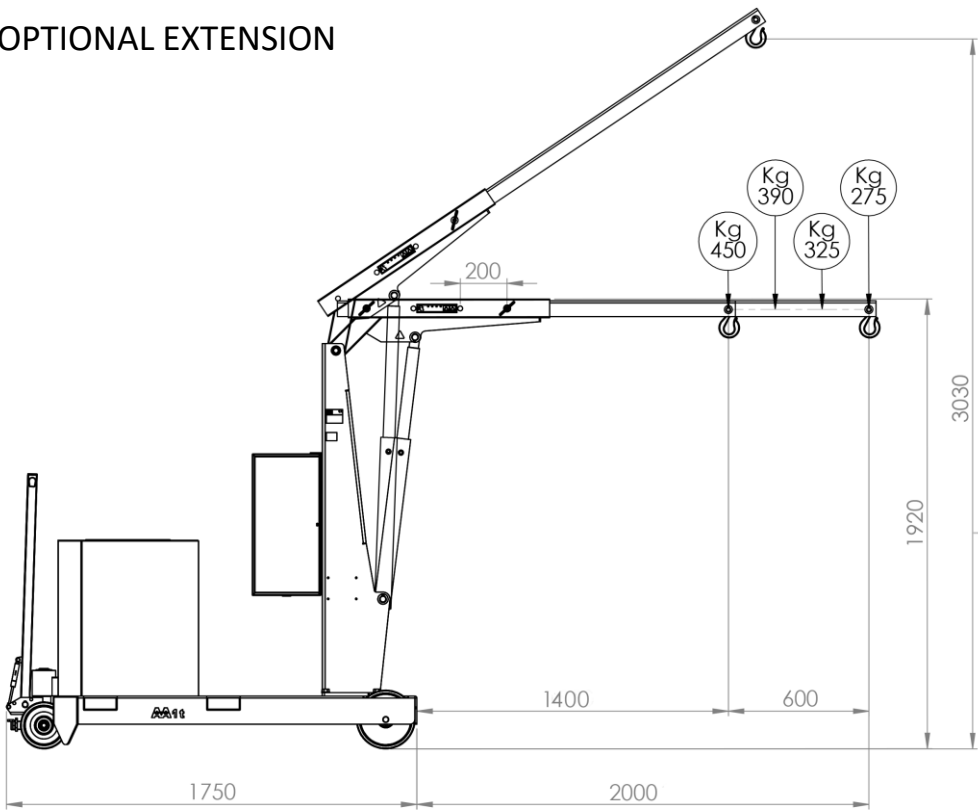

Suitable for  
lifting  
operations in  
logistics

# GZ1000B

## TECHNICAL DRAWINGS, DIMENSIONS AND CAPACITIES

Recommended for lifting operations that do not require an accurate load positioning in the descent phase

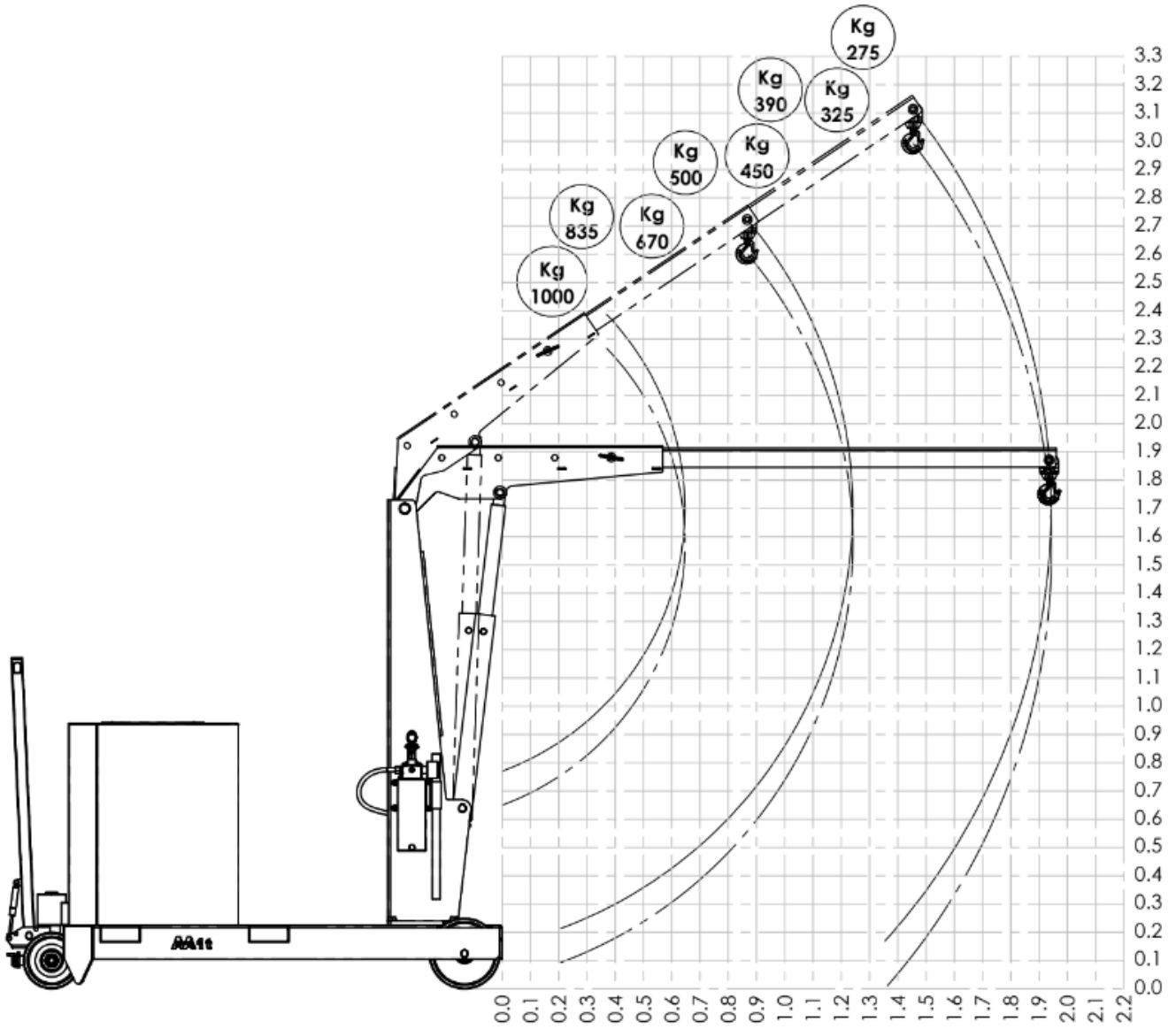



**GZ1000BP**  
**CAPACITY 1000 KG**  
**COUNTERBALANCED CRANE – FIX JIB ARM – SINGLE SPEED POWERED LIFT**  
**JIB ARM - LOWER CONTROLLED BY PENDANT PROGRESSIVE LEVER**



CAPACITY WITH OPTIONAL EXTENDED JIB ARM		
POS.	Length	Capacity
	[mm]	GZ1000P [kg]
1	1400	450
2	1600	390
3	1800	325
4	2000	275

CAPACITY AND DIMENSIONS WITH STANDARD JIB ARM		
POS.	Length	Capacity
	[mm]	GZ1000P [kg]
1	650	1000
2	850	835
3	1050	670
4	1250	500

Technical data	UM	GZ1000P
Weight	[kg]	1190
Max capacity	[kg]	1000
Max pressure	[bar]	160
Tank capacity	[Liters]	3
Cylinder stroke	[mm]	550

1 battery	[V]	12
	[A]	80
Battery charger	[V]	220
	[A]	12

La GZ1000BP is equipped with a pendant lever for lifting a load at a single speed and operating a progressive descent . This requirement is indispensable when millimeter accuracy is required during the positioning of the load.

The arm is extendable in 4 positions and an optional arm extension is available to get a maximum outreach of 2000 mm. Built-in high-frequency charger. Charge level indicator. Battery 12V 80A.





# GZ1000BP

## TECHNICAL DRAWINGS, DIMENSIONS AND CAPACITIES

Recommended for operations where an accurate load positioning is needed

### STANDARD EXTENSION

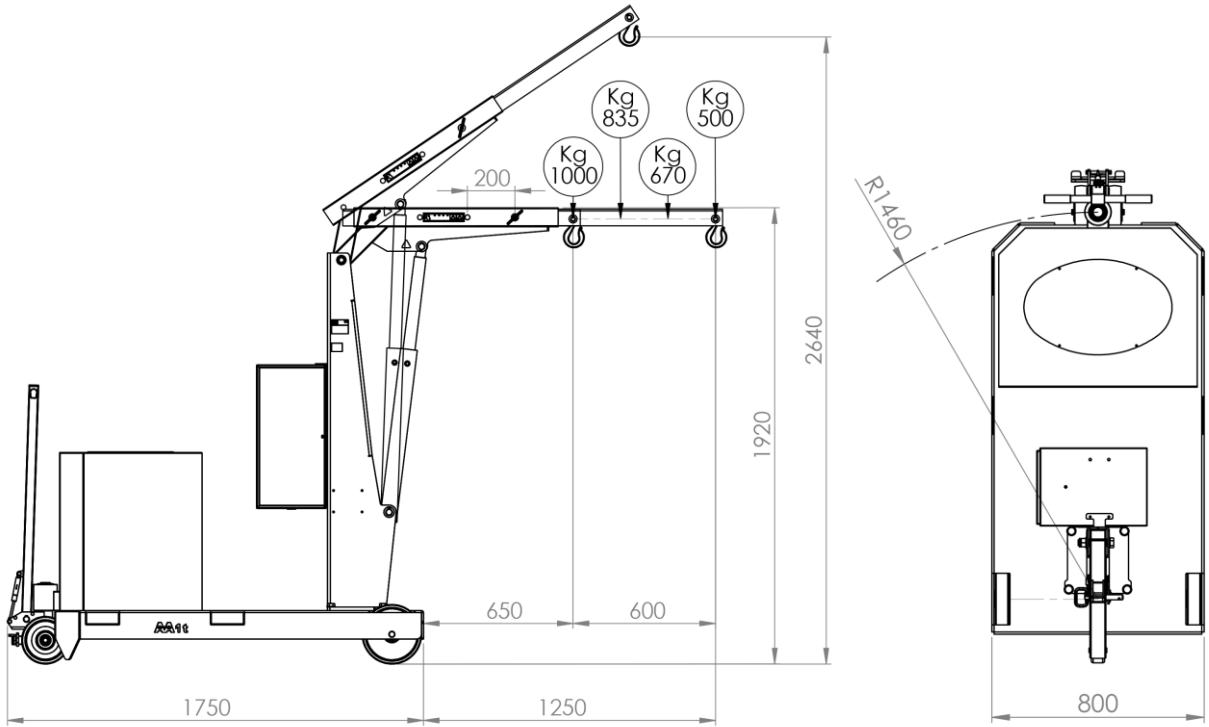

### OPTIONAL EXTENSION

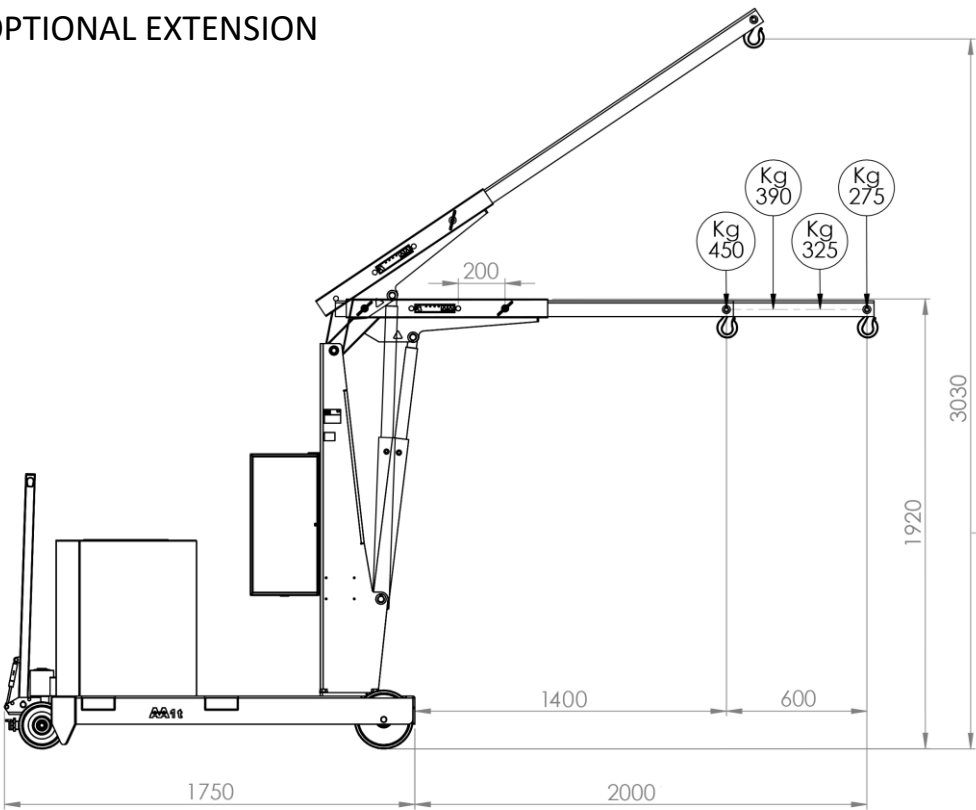

Millimeter accuracy in the positioning of the load in the descent phase

# GZ1000BP

## TECHNICAL DRAWINGS, DIMENSIONS AND CAPACITIES

Recommended for operations where an accurate load positioning is needed

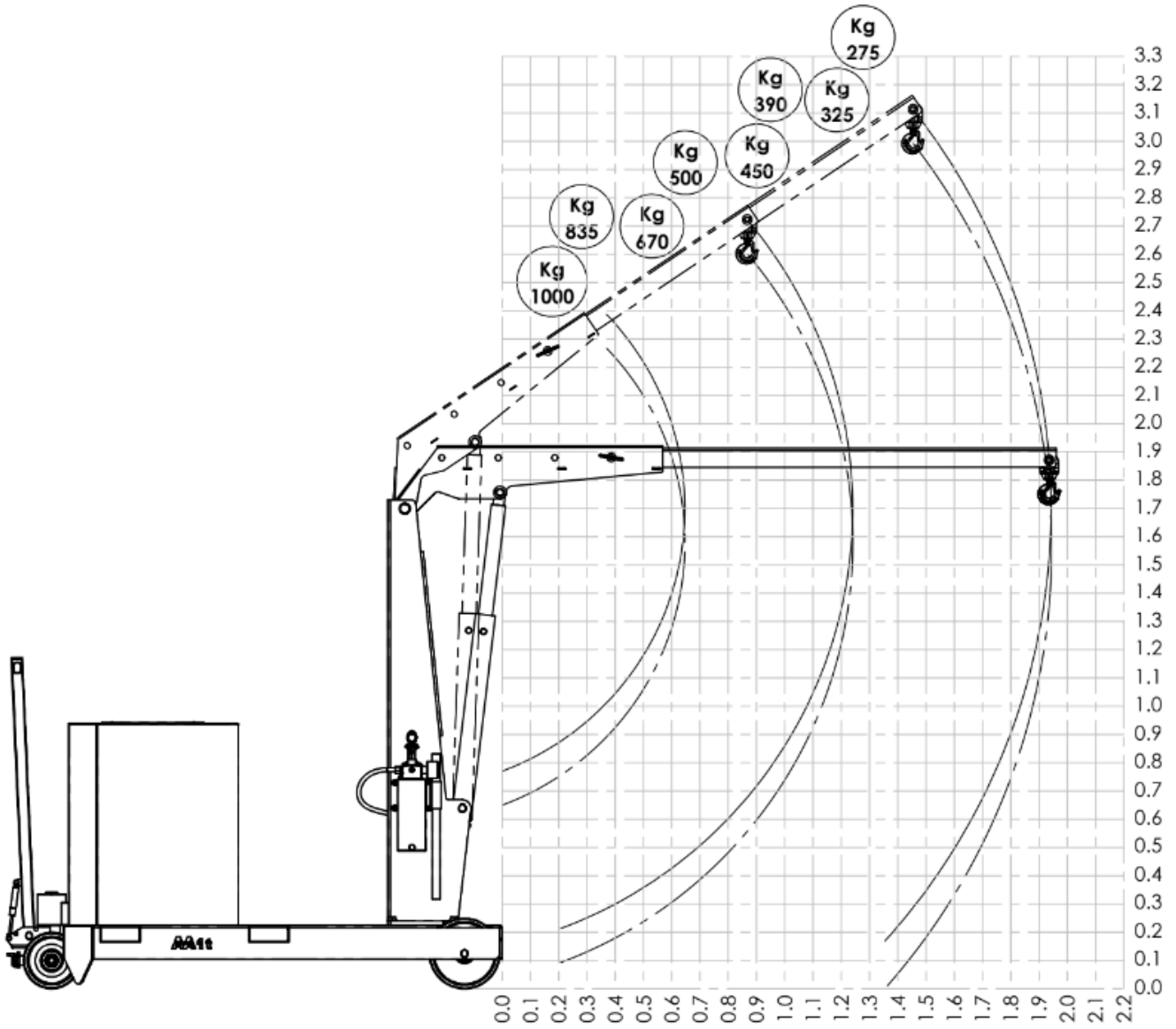

**GZ1000BSE**  
CAPACITY 1000 KG  
COUNTERBALANCED CRANE , FIX JIB ARM , POWERED LIFT /LOWER &  
POWERED EXTEND/RETRACT JIB ARM WITH PROGRESSIVE SPEED

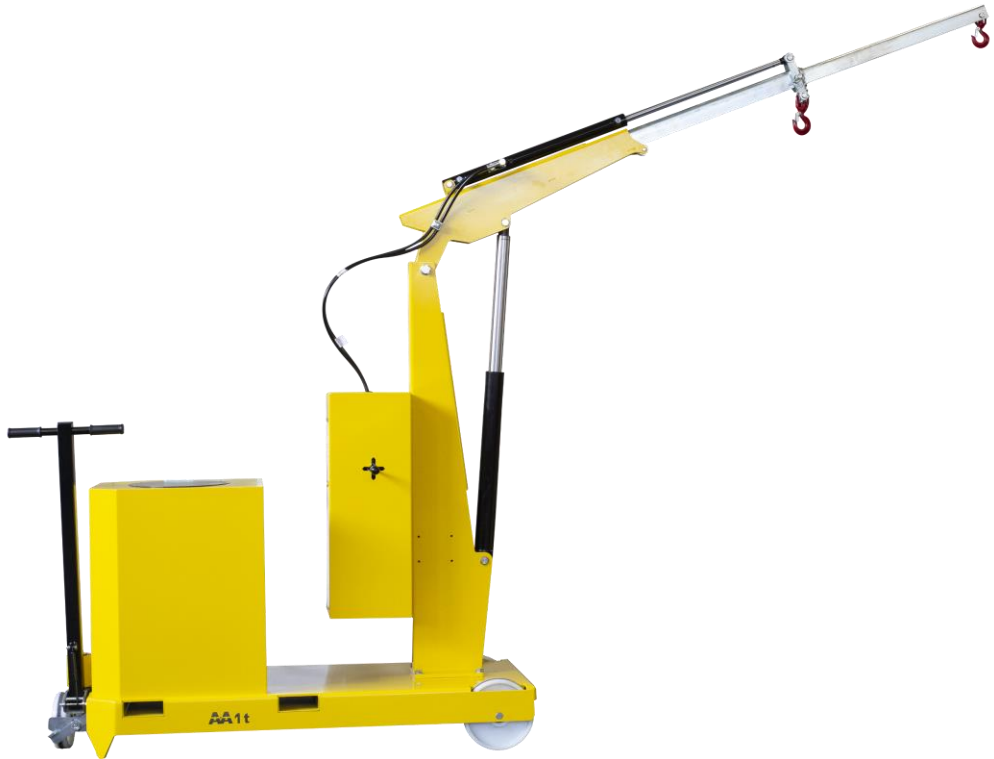

Technical data	UM	GZ1000BSE
Weight	[kg]	1195
Max capacity	[kg]	1000
Max pressure	[bar]	160
Tank capacity	[Liters]	3
Cylinder stroke	[mm]	550

CAPACITY AND DIMENSIONS WITH STANDARD JIB ARM	
Length	Capacity
[mm]	[kg]
from 650 to 1250	from 1000 to 500

CAPACITY WITH OPTIONAL EXTENDED JIB ARM	
Length	Capacity
[mm]	[kg]
from 1400 to 2000	FIX CAPACITY 200

1 battery	[V]	12
	[A]	80
Battery charger	[V]	220
	[A]	12

La GZ1000BSE is equipped with an electric controlled jib arm . It is equipped with a 4 way fine control lever controls for :

- Lifting the jib arm
- Lowering the jib arm
- Extending the jib arm
- Retracting the jib arm

All movements (arm and extension) are electric controlled, progressive and adjustable by the operator with extreme precision. Controlled descent system with the engine off.

**Model GZ1000BSE is the most popular model for awkward placements from the ground onto 3D machines, lathes, over perimeter protections, narrow openings, etc. and in all those applications where there is no space to move the load with a forklift or other large sizes lifting equipment.**



Battery charger

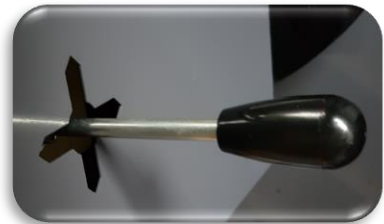

Detail of the 4 way fine control lever

# GZ1000BSE

## TECHNICAL DRAWINGS, DIMENSIONS AND CAPACITIES

The right crane for endless applications  
and the best performance

### STANDARD EXTENSION

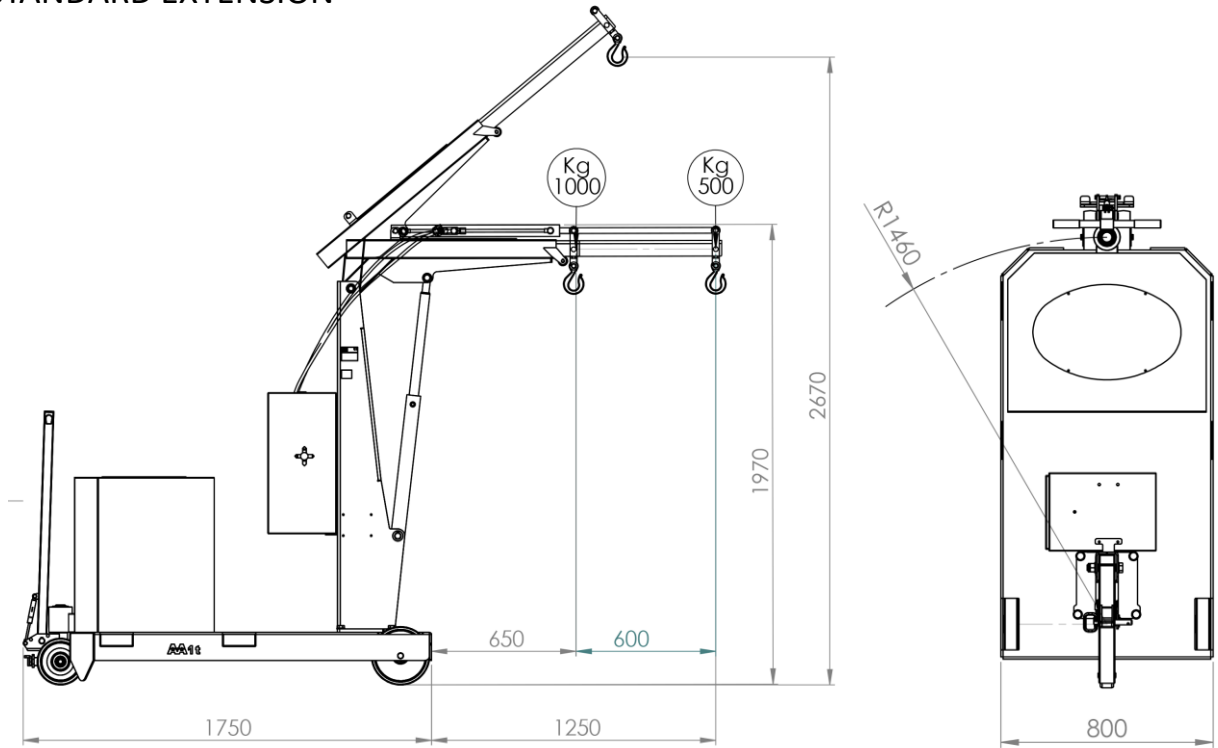

### OPTIONAL EXTENSION

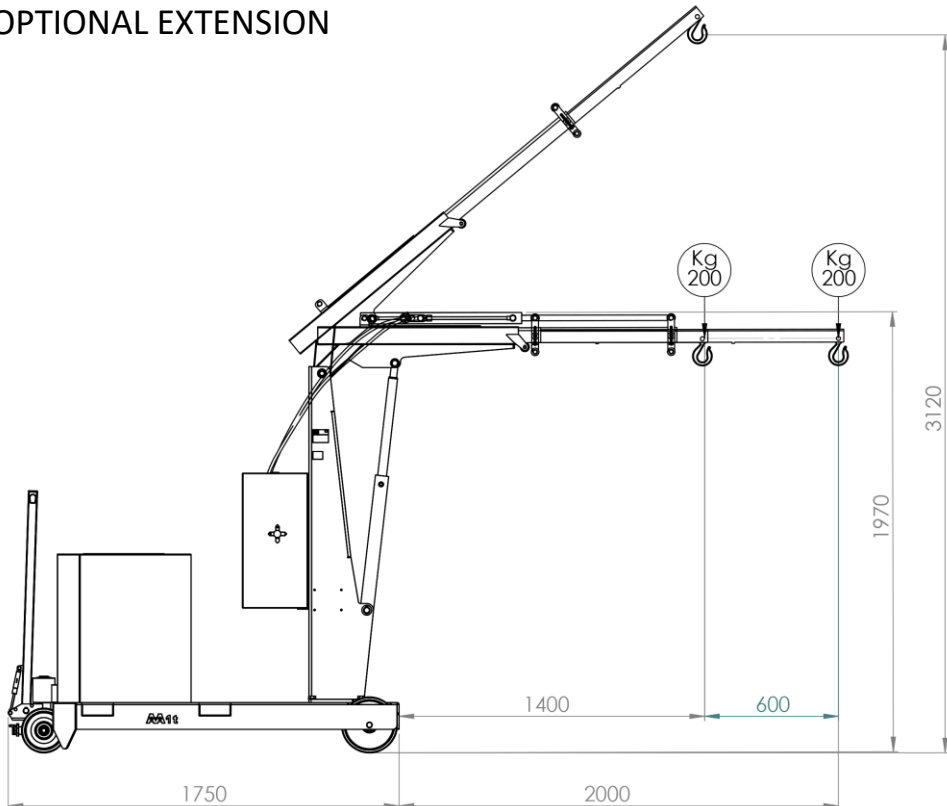

Powered  
lift/lower and  
powered  
extend/retract jib  
arm with  
progressive  
speed

**GZ1000BSE**  
**TECHNICAL DRAWINGS, DIMENSIONS AND CAPACITIES**  
 The right crane for endless applications  
 and the best performance

